

Embedded Multi-Media Card (e.MMC)

Flash Storage Specification e.MMC 5.1 HS400

EM74H08HVAGA-H

Revision History

Rev	Date	Comments
1.00	October 30, 2023	Initial release
1.01	May 02, 2024	Updated CID Register (MID / OID / PNM)
1.02	November 06, 2024	Revised the e.MMC wording

Etron Technology, Inc. reserves the right to change products or specification without notice.

Contents

1	Introduction.....	6
1.1.	Product Features	6
1.2.	e.MMC Specific Feature	7
2	Product Description	8
2.1.	Device Block Diagram	8
2.2.	Package Configuration	9
2.3.	Ball Assignment	10
2.4.	Device Performance	11
2.5.	Power Consumption	11
2.6.	Device and Partition Capacity	12
2.7.	e.MMC Bus Modes	12
3	Device Register.....	13
3.1.	Card Identification Register (CID).....	13
3.2.	Card Specific Data Register [CSD].....	13
3.3.	Extended Card Specific Data Register [EXT_CSD]	13
4	Operating Temperature and Voltage Range	21
5	Package Outline Information	22

List of Figures

Figure 2-1. Block Diagram	8
Figure 2-2. 153-FBGA Ball Assignment (Top View)	9
Figure 5-1. Package Outline Drawing Information for FBGA	23

List of Tables

Table 1-1. Product Information	6
Table 2-1. Ball Descriptions	10
Table 2-2. Sequential Read / Write Performance	11
Table 2-3. Device Power Consumption	11
Table 2-4. Partition Capacity	12
Table 2-5. e.MMC Bus Modes	12
Table 3-1. e.MMC Register	13
Table 4-1. Device Operating Temperature	21
Table 4-2. Device Operating Voltage	21
Table 5-1. FBGA (11.5 x 13 x 0.8mm) Dimension Table	22

1 Introduction

The e.MMC products follow the JEDEC e.MMC 5.1 standards. It is an ideal universal storage solution for many electronic devices, including smart phones, tablets, PDAs, eBook readers, digital cameras, recorders, MP3, MP4 players, electronic learning products, digital TVs and set-top boxes. e.MMC encloses the MLC NAND and e.MMC controller inside as one JEDEC standard package, providing a standard interface to the host. The e.MMC controller directly manages NAND flash, including ECC, wear-leveling, IOPS optimization and read sensing.

1.1. Product Features

- **Packaged managed NAND flash memory with e.MMC 5.1 interface**
- **Backward compatible with all prior e.MMC specification revisions**
- **Operating Voltage Support:**
 - V_{CC} : (3.3V) 2.7V ~ 3.6V
 - V_{CCQ} : (1.8V) 1.7V ~ 1.95V / (3.3V) 2.7V ~ 3.6V
- **Temperature:**
 - Operating Temperature: TC = -25°C to +85°C
 - Storage without operation: -40°C to +85°C
- **Compliant with e.MMC 5.1 JEDEC Standard Number JESD84-B51**
- **Embedded Multi-Media storage in a single Multi-Chip package**
- **Package: 153-ball 11.5 x 13.0 x 0.8mm FBGA package**

Table 1-1. Product Information

Part Number	NAND Density	V_{CC}	V_{CCQ}	Package
EM74H08HVAGA-H	4 GB	3.3V	1.8V/3.3V	FBGA

1.2. e.MMC Specific Feature

- **High-speed e.MMC protocol**
- **Variable clock frequencies of 0-200MHz**
- **Ten-wire bus interface (clock, 1 bit command, 8 bit data bus) with an optional hardware reset**
- **Supports three different data bus widths: 1 bit(default), 4 bits, 8 bits**
- **Bus modes:**
 - Single data transfer rate: up to 52MB/s (using 8 parallel data lines at 52MHz)
 - Dual data rate mode (DDR-104) : up to 104MB/s @ 52MHz
 - High speed, single data rate mode (HS-200) : up to 200MB/s @ 200MHz
 - High speed, dual data rate mode (HS-400) : up to 400MB/s @ 200MHz
- **Supports alternate boot operation mode to provide a simple boot sequence method**
- **Supports SLEEP/AWAKE (CMD5)**
- **Host initiated explicit sleep mode for power saving**
- **Enhanced write protection with permanent and partial write protection options**
- **Multiple user data partition with enhanced attribute for increased reliability**
- **Error free memory access**
 - Cyclic Redundancy Code (CRC) for reliable command and data communication
 - Internal error correction code (ECC) for improved data storage integrity
 - Internal enhanced data management algorithm
 - Data protection for sudden power failure during program operations
- **Security**
 - Secure block erase commands
 - Enhanced write protection with permanent and partial protection options
- **Power off notification**
- **Field firmware update (FFU)**
- **Production state awareness**
- **Device health report**
- **Command queuing**
- **Enhanced strobe**
- **Cache flushing report**
- **Cache barrier**
- **Background operation control & High Priority Interrupt (HPI)**
- **RPMB throughput improvement**
- **Secure write protection**
- **Pre EOL information**
- **Optimal size**

2 Product Description

The e.MMC products conform to the JEDEC e.MMC 5.1 standard. These devices are an ideal universal storage solution for many commercial and industrial applications. In a single integrated packaged device, e.MMC combines multi-level cell (MLC) NAND flash memory with an onboard e.MMC controller, providing an industry standard interface to the host system. The integrated e.MMC controller directly manages NAND flash media which relieves the host processor of these tasks, including flash media error control, wear-leveling, NAND flash management and performance optimization. Future revision to the JEDEC e.MMC standard will always maintain backward compatibility. The industry standard interface to the host processor ensures compatibility across future NAND flash generations as well, easing product sustainment throughout the product life cycle.

2.1. Device Block Diagram

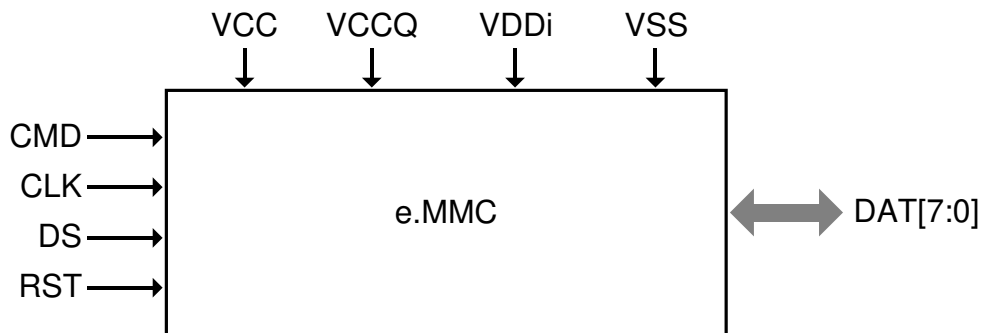

Figure 2-1. Block Diagram

2.2. Package Configuration

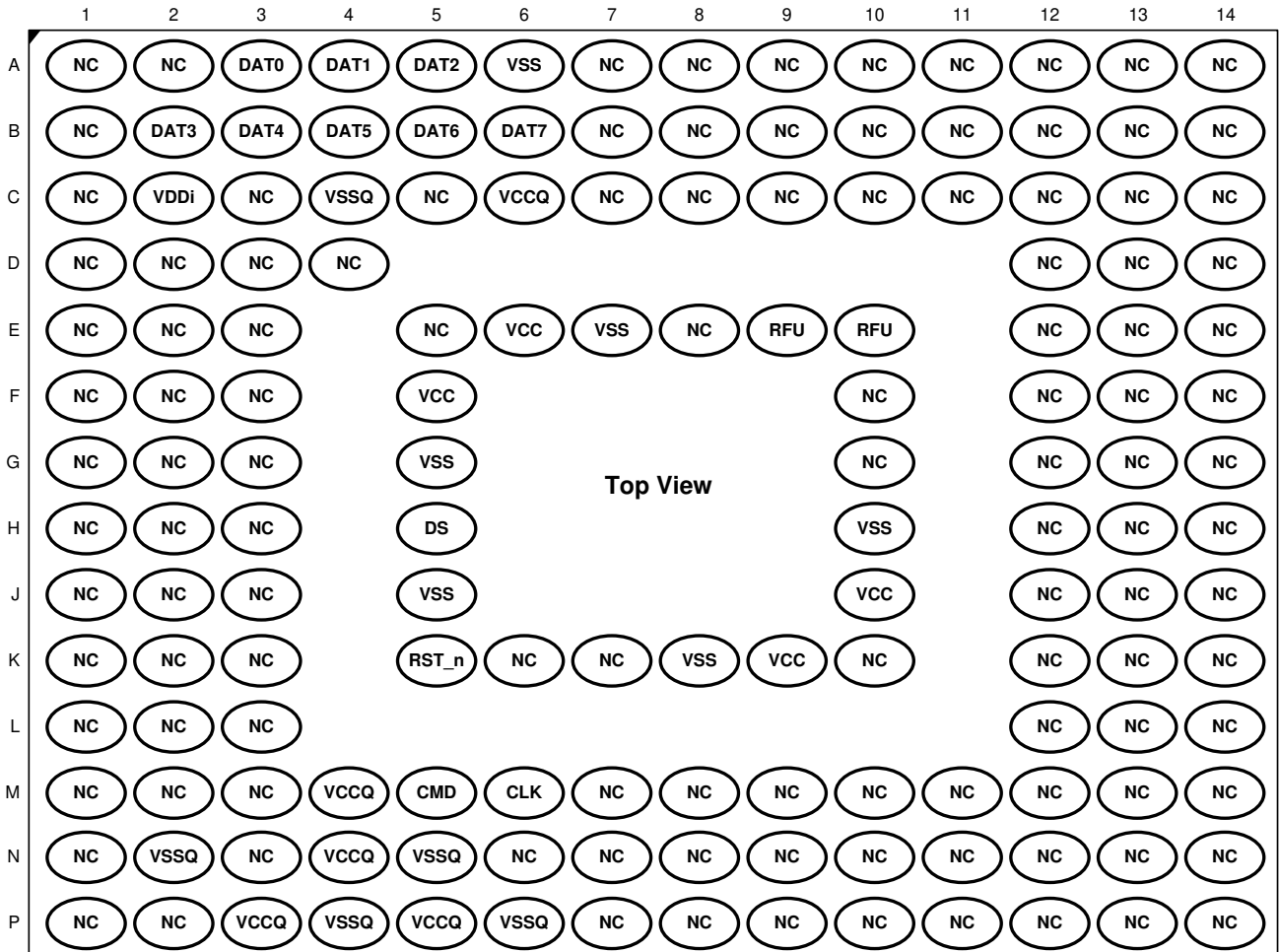

Figure 2-2. 153-FBGA Ball Assignment (Top View)

2.3. Ball Assignment

Table 2-1. Ball Descriptions

Name	Type	Description
CLK	I	Clock: Each cycle of this signal directs a one bit transfer on the command and either a one bit (1x) or a two bits transfer (2x) on all the data lines. The frequency may vary between zero and the maximum clock frequency.
DAT[7:0]	I/O/PP	Data: These are bidirectional data channels. The DAT signals operate in push-pull mode. These bidirectional signals are driven by either the e.MMC device or the host controller. By default, after power up or reset, only DAT0 is used for data transfer. A wider data bus can be configured for data transfer, using either DAT0-DAT3 or DAT0-DAT7, by the e.MMC host controller. The e.MMC device includes internal pull-ups for data lines DAT1-DAT7. Immediately after entering the 4-bit mode, the device disconnects the internal pull ups of lines DAT1, DAT2, and DAT3. Correspondingly, immediately after entering to the 8-bit mode, the device disconnects the internal pull-ups of lines DAT1-DAT7.
CMD	I/O/PP/OD	Command: This signal is a bidirectional command channel used for device initialization and transfer of commands. The CMD signal has two operation modes: open-drain for initialization mode, and push-pull for fast command transfer. Commands are sent from the e.MMC host controller to the e.MMC device and responses are sent from the device to the host.
DS	O	This signal is generated by the device and used for output in HS400 mode. The frequency of this signal follows the frequency of CLK. For data output each cycle of this signal directs two bits transfer(2x) on the data - one bit for positive edge and the other bit for negative edge. For CRC status response output and CMD response output (enabled only HS400 enhanced strobe mode), the CRC status and CMD Response are latched on the positive edge only, and don't care on the negative edge.
RST_n	I	Hardware Reset: By default, hardware reset is disabled and must be enabled in the EXT_CSD register if used. Otherwise, it can be left un-connected.
RFU	-	Reserved for future use: These pins are not internally connected. Leave floating
NC	-	Not Connected: These pins are not internally connected. Signals can be routed through these balls to ease printed circuit board design.
VDDi	-	Internal Voltage Node: Note that this is not a power supply input. This pin provides access to the output of an internal voltage regulator to allow for the connection of an external Creg capacitor.
VCC	S	Supply voltage for core
VDDQ	S	Supply voltage for I/O
VSS	S	Supply ground for core
VSSQ	S	Supply ground for I/O
Note: I=Input; O=Output; P=Push-Pull; OD=Open Drain; NC=Not Connected(or logical high); S=Power Supply		

2.4. Device Performance

The following table provides sequential read and write speeds for all capacities. Performance numbers may vary under different operating conditions. Values are given in HS400 bus mode.

Table 2-2. Sequential Read / Write Performance

Product	Typical value (MB/s)		Dynamic booster value (MB/s)	
	Read Sequential	Write Sequential	Read Sequential	Write Sequential
EM74H08HVAGA-H	280	17	280	55

Note 1: Performance numbers might be subject to changes without notice.

2.5. Power Consumption

The device current consumption for various device configurations is defined in the power level field of the EXT_CSD register. The table below summarizes the power consumption values.

Table 2-3. Device Power Consumption

Product	Read(mA)		Write(mA)		Standby(mA)	
	VCCQ(1.8V)	VCC(3.3V)	VCCQ(1.8V)	VCC(3.3V)	VCCQ(1.8V)	VCC(3.3V)
EM74H08HVAGA-H	91.83	75.79	30.52	25.80	0.050	0.035

Note 1: Values given for an 8-bit bus width, a clock frequency of 200MHz DDR mode, VCC= 3.3V±5%, VCCQ=1.8V±5%

Note 2: Standby current is measured at VCC=3.3V±5%, 8-bit bus width without clock frequency.

Note 3: Current numbers might be subject to changes without notice.

2.6. Device and Partition Capacity

The device NAND flash capacity is divided across two boot partitions (2048 KB each), a Replay Protected Memory Block (RPMB) partition (512 KB), and the main user storage area. Four additional general purpose storage partitions can be created from the user partition. These partitions can be factory preconfigured or configured in-field by following the procedure outlined in the JEDEC e.MMC specification JESD84-B51. A small portion of the NAND storage capacity is used for the storage of the onboard controller firmware and mapping tables. Additionally, several NAND blocks are held in reserve to boost performance and extend the life of the e.MMC device. The following table determines the specific capacity of each partition. This information is reported in the device EXT_CSD registers. The contents of this register are also listed in the Appendix.

Table 2-4. Partition Capacity

User density	Boot partition 1	Boot partition 2	RPMB
3827957760 Bytes	2048 KB	2048 KB	512 KB

2.7. e.MMC Bus Modes

The device supports all bus modes defined in the JEDEC e.MMC 5.1 specification. The following table summarizes these patterns.

Table 2-5. e.MMC Bus Modes

Mode	Data Rate	IO Voltage	Bus Width	CLK Frequency	Maximum Data Bus Throughput
Legacy MMC	Single	3.3V / 1.8V	1, 4, 8	0 – 26 MHz	26 MB/s
High Speed SDR	Single	3.3V / 1.8V	4, 8	0 – 52 MHz	52 MB/s
High Speed DDR	Dual	3.3V / 1.8V	4, 8	0 – 52 MHz	104 MB/s
HS200	Single	1.8V	4, 8	0 – 200 MHz	200 MB/s
HS400	Dual	1.8V	8	0 – 200 MHz	400 MB/s

3 Device Register

3.1. Card Identification Register (CID)

The Card Identification (CID) register is a 128-bit register that contains device identification information used during the e.MMC protocol device identification phase. Refer to JEDEC Standard Specification No.JESD84-B51 for details.

3.2. Card Specific Data Register [CSD]

The Card-Specific Data (CSD) register provides information on how to access the contents stored in e.MMC. The CSD registers are used to define the error correction type, maximum data access time, data transfer speed, data format...etc. Refer to JEDEC Standard Specification No.JESD84-B51 for details.

3.3. Extended Card Specific Data Register [EXT_CSD]

The Extended CSD register defines the Device properties and selected modes. It is 512 bytes long. The most significant 320 bytes are the Properties segment, which defines the Device capabilities and cannot be modified by the host. The lower 192 bytes are the Modes segment, which defines the configuration the Device is working in. These modes can be changed by the host by means of the SWITCH command. Refer to JEDEC Standard Specification No.JESD84-B51 for details.

Table 3-1. e.MMC Register

Name	Width (Bytes)	Description	Implementation
CID	16	Device Identification number, an individual number for identification.	Mandatory
RCA	2	Relative Device Address is the Device system address, dynamically assigned by the host during initialization.	Mandatory
DSR	2	Driver Stage Register, to configure the Device's output drivers.	Optional
CSD	16	Device Specific Data, information about the Device operation conditions.	Mandatory
OCR	4	Operation Conditions Register. Used by a special broadcast command to identify the voltage type of the Device.	Mandatory
EXT_CSD	512	Extended Device Specific Data. Contains information about the Device capabilities and selected modes. Introduced in standard v4.0	Mandatory

Register Settings:

Applied Products: EM74H08HVAGA-H (ST74HH)

OCR Register Setting:

OCR Register Definitions OCR bit	VDD voltage window	High Voltage Multi-Media Card	Dual voltage Multi-Media Card and e.MMC
[6:0]	Reserved	00 00000b	00 00000b
[7]	1.70 - 1.95V	0b	1b
[14:8]	2.0-2.6V	000 0000b	000 0000b
[23:15]	2.7-3.6V	1 1111 1111b	1 1111 1111b
[28:24]	Reserved	0 0000b	0 0000b
[30:29]	Access Mode	00b (byte mode) 10b (sector mode)	00b (byte mode) 10b (sector mode)
[31]	(Device power up status bit (busy) ¹)		
Note1 : This bit is set to LOW if the Device has not finished the power up routine.			

CID Register Setting:

CID Fields Name	Field	Width	CID slice	Value
Manufacturer ID	MID	8	[127:120]	D5h
Reserved		6	[119:114]	0h
Device/BGA	CBX	2	[113:112]	1h
OEM/Application ID	OID	8	[111:104]	20h
Product name	PNM	48	[103:56]	(535437344848h) ST74HH
Product revision	PRV	8	[55:48]	01h
Product serial number	PSN	32	[47:16]	Random by Production
Manufacturing date	MDT	8	[15:8]	month, year
CRC7 checksum	CRC	7	[7:1]	- (Note 1)
not used, always "1"	-	1	[0]	1h

Note1. The description are same as e.MMC JEDEC standard.

CSD Register Setting:

Name	Field	Width	CSD-slice	Value
CSD structure	CSD_STRUCTURE	2	[127:126]	3h
System specification version	SPEC_VERS	4	[125:122]	4h
Reserved	-	2	[121:120]	0h
Data read access-time 1	TAAC	8	[119:112]	4Fh
Data read access-time 2 in CLK cycles (NSAC*100)	NSAC	8	[111:104]	1h
Max. bus clock frequency	TRAN_SPEED	8	[103:96]	32h
Device command classes	CCC	12	[95:84]	8F5h
Max. read data block length	READ_BL_LEN	4	[83:80]	9h
Partial blocks for read allowed	READ_BL_PARTIAL	1	[79:79]	0h
Write block misalignment	WRITE_BLK_MISALIGN	1	[78:78]	0h
Read block misalignment	READ_BLK_MISALIGN	1	[77:77]	0h
DSR implemented	DSR_IMP	1	[76:76]	0h
Reserved	-	2	[75:74]	0h
Device size	C_SIZE	12	[73:62]	FFFh
Max. read current @ VDD min	VDD_R_CURR_MIN	3	[61:59]	7h
Max. read current @ VDD max	VDD_R_CURR_MAX	3	[58:56]	7h
Max. write current @ VDD min	VDD_W_CURR_MIN	3	[55:53]	7h
Max. write current @ VDD max	VDD_W_CURR_MAX	3	[52:50]	7h
Device size multiplier	C_SIZE_MULT	3	[49:47]	7h
Erase group size	ERASE_GRP_SIZE	5	[46:42]	17h
Erase group size multiplier	ERASE_GRP_MULT	5	[41:37]	1Fh
Write protect group size	WP_GRP_SIZE	5	[36:32]	0Fh
Write protect group enable	WP_GRP_ENABLE	1	[31:31]	1h
Manufacturer default ECC	DEFAULT_ECC	2	[30:29]	0h
Write speed factor	R2W_FACTOR	3	[28:26]	2h
Max. write data block length	WRITE_BL_LEN	4	[25:22]	9h
Partial blocks for write allowed	WRITE_BL_PARTIAL	1	[21:21]	0h
Reserved	-	4	[20:17]	0h
Content protection application	CONTENT_PROT_APP	1	[16:16]	0h
File format group	FILE_FORMAT_GRP	1	[15:15]	0h
Copy flag (OTP)	COPY	1	[14:14]	0h
Permanent write protection	PERM_WRITE_PROTECT	1	[13:13]	0h
Temporary write protection	TMP_WRITE_PROTECT	1	[12:12]	0h
File format	FILE_FORMAT	2	[11:10]	0h
ECC code	ECC	2	[9:8]	0h
CRC	CRC	7	[7:1]	0Bh
Not used, always '1'	-	1	[0:0]	1h

Extended CSD Register:

Name	Field	Size (Bytes)	CSD-slice	Value
Properties Segment				
Reserved (note1)	-	6	[511:506]	0h
Extended Security Commands Error	EXT_SECURITY_ERR	1	[505]	0h
Supported Command Sets	S_CMD_SET	1	[504]	1h
HPI features	HPI_FEATURES	1	[503]	1h
Background operations support	BKOPS_SUPPORT	1	[502]	1h
Max packed read commands	MAX_PACKED_READS	1	[501]	3Ch
Max packed write commands	MAX_PACKED_WRITES	1	[500]	20h
Data Tag Support	DATA_TAG_SUPPORT	1	[499]	1h
Tag Unit Size	TAG_UNIT_SIZE	1	[498]	3h
Tag Resources Size	TAG_RES_SIZE	1	[497]	0h
Context management capabilities	CONTEXT_CAPABILITIES	1	[496]	5h
Large Unit size	LARGE_UNIT_SIZE_M1	1	[495]	0Bh
Extended partitions attribute support	EXT_SUPPORT	1	[494]	3h
Supported modes	SUPPORTED_MODES	1	[493]	01h
FFU features	FFU_FEATURES	1	[492]	0h
Operation codes timeout	OPERATION_CODE_TIME_OUT	1	[491]	0h
FFU Argument	FFU_ARG	4	[490:487]	65535
Barrier support	BARRIER_SUPPORT	1	[486:486]	1h
Reserved (note1)	Reserved	177	[485:309]	-
CMD Queuing Support	CMQ_SUPPORT	1	[308:308]	1h
CMD Queuing Depth	CMQ_DEPTH	1	[307:307]	0Fh
Reserved (note1)	Reserved	1	[306:306]	-
Number of FW sectors correctly programmed	NUMBER_OF_FW_SECTORS_CORRECTLY_PROGRAMMED	4	[305:302]	0h
Vendor proprietary health report	VENDOR_PROPRIETARY_HEALTH_REPORT	32	[301:270]	0h
Device life time estimation type B	DEVICE_LIFE_TIME_EST_TYP_B	1	[269]	1h
Device life time estimation type A	DEVICE_LIFE_TIME_EST_TYP_A	1	[268]	1h
Pre EOL information	PRE_EOL_INFO	1	[267]	1h
Optimal read size	OPTIMAL_READ_SIZE	1	[266]	1h
Optimal write size	OPTIMAL_WRITE_SIZE	1	[265]	4h
Optimal trim unit size	OPTIMAL_TRIM_UNIT_SIZE	1	[264]	1h
Device version	DEVICE_VERSION	2	[263:262]	0h
Firmware version	FIRMWARE_VERSION	8	[261:254]	1h*
Power class for 200MHz, DDR at VCC=3.6V	PWR_CL_DDR_200_360	1	[253]	0h

Cache size	CACHE_SIZE	4	[252:249]	512
Generic CMD6 timeout	GENERIC_CMD6_TIME	1	[248]	19h
Power off notification(long) time out	POWER_OFF_LONG_TIME	1	[247]	3h
Background operations status	BKOPS_STATUS	1	[246]	0h
Number of correctly programmed sectors	CORRECTLY_PRG_SECTORS_NUM	4	[245:242]	0h
1st initialization time after partitioning	INI_TIMEOUT_AP	1	[241]	64h
Cache Flushing Policy	CACHE_FLUSH_POLICY	1	[240]	1h
Power class for 52MHz, DDR at 3.6V	PWR_CL_DDR_52_360	1	[239]	0h
Power class for 52MHz, DDR at 1.95V	PWR_CL_DDR_52_195	1	[238]	0h
Power class for 200MHz at 3.6V	PWR_CL_200_360	1	[237]	0h
Power class for 200MHz, at 1.95V	PWR_CL_200_195	1	[236]	0h
Minimum Write Performance for 8bit at 52MHz in DDR mode	MIN_PERF_DDR_W_8_52	1	[235]	0h
Minimum Read Performance for 8bit at 52MHz in DDR mode	MIN_PERF_DDR_R_8_52	1	[234]	0h
Reserved (note1)	-	1	[233]	-
TRIM Multiplier	TRIM_MULT	1	[232]	5h
Secure Feature support	SEC_FEATURE_SUPPORT	1	[231]	55h
Secure Erase Multiplier	SEC_ERASE_MULT	1	[230]	1Eh
Secure TRIM Multiplier	SEC_TRIM_MULT	1	[229]	1Eh
Boot information	BOOT_INFO	1	[228]	7h
Reserved (note1)	-	1	[227]	-
Boot partition size	BOOT_SIZE_MULT1	1	[226]	10h
Access size	ACC_SIZE	1	[225]	6h
High-capacity erase unit size	HC_ERASE_GRP_SIZE	1	[224]	1h
High-capacity erase timeout	ERASE_TIMEOUT_MULT	1	[223]	5h
Reliable write sector count	REL_WR_SEC_C	1	[222]	1h
High-capacity write protect group size	HC_WP_GRP_SIZE	1	[221]	10h
Sleep current (VCC)	S_C_VCC	1	[220]	8h
Sleep current (VCCQ)	S_C_VCCQ	1	[219]	8h
Production state awareness Timeout	PRODUCTION_STATE_AWARENESS_TIMEOUT	1	[218]	14h
Sleep/awake timeout	S_A_TIMEOUT	1	[217]	13h
Sleep Notification time out	SLEEP_NOTIFICATION_TIME	1	[216]	0Fh
Sector Count	SEC_COUNT	4	[215:212]	00721500h
Secure Write Protect Information	SECURE_WP_INFO	1	[211]	1h
Minimum Write Performance for 8bit at 52MHz	MIN_PERF_W_8_52	1	[210]	8h

Minimum Read Performance for 8bit at 52MHz	MIN_PERF_R_8_52	1	[209]	8h
Minimum Write Performance for 8bit at 26MHz, for 4bit at 52MHz	MIN_PERF_W_8_26_4_52	1	[208]	8h
Minimum Read Performance for 8bit at 26MHz, for 4bit at 52MHz	MIN_PERF_R_8_26_4_52	1	[207]	8h
Minimum Write Performance for 4bit at 26MHz	MIN_PERF_W_4_26	1	[206]	8h
Minimum Read Performance for 4bit at 26MHz	MIN_PERF_R_4_26	1	[205]	8h
Reserved (note1)	–	1	[204]	–
Power class for 26MHz at 3.6V 1 R	PWR_CL_26_360	1	[203]	0h
Power class for 52MHz at 3.6V 1 R	PWR_CL_52_360	1	[202]	0h
Power class for 26MHz at 1.95V 1 R	PWR_CL_26_195	1	[201]	0h
Power class for 52MHz at 1.95V 1 R	PWR_CL_52_195	1	[200]	0h
Partition switching timing	PARTITION_SWITCH_TIME	1	[199]	3h
Out-of-interrupt busy timing	OUT_OF_INTERRUPT_TIME	1	[198]	8h
I/O Driver Strength	DRIVER_STRENGTH	1	[197]	1Fh
Device type	CARD_TYPE	1	[196]	57h
Reserved (note1)	–	1	[195]	–
CSD structure version	CSD_STRUCTURE	1	[194]	2h
Reserved (note1)	–	1	[193]	–
Extended CSD revision	EXT_CSD_REV	1	[192]	08h
Modes Segment				
Command set	CMD_SET	1	[191]	0h
Reserved (note1)	–	1	[190]	–
Command set revision	CMD_SET_REV	1	[189]	0h
Reserved (note1)	–	1	[188]	–
Power class	POWER_CLASS	1	[187]	0h
Reserved (note1)	–	1	[186]	–
High-speed interface timing	HS_TIMING	1	[185]	1h (note 3)
Strobe Support	STROBE_SUPPORT	1	[184]	1h
Bus width mode	BUS_WIDTH	1	[183]	2h (note 4)
Reserved (note1)	–	1	[182]	–
Erased memory content	ERASED_MEM_CONT	1	[181]	0h
Reserved (note1)	–	1	[180]	–
Partition configuration	PARTITION_CONFIG	1	[179]	0h
Boot config protection	BOOT_CONFIG_PROT	1	[178]	0h
Boot bus Conditions	BOOT_BUS_CONDITIONS	1	[177]	0h
Reserved (note1)	–	1	[176]	–
High-density erase group definition	ERASE_GROUP_DEF	1	[175]	0h

Boot write protection status registers	BOOT_WP_STATUS	1	[174]	0h
Boot area write protection register	BOOT_WP	1	[173]	0h
Reserved (note1)	–	1	[172]	–
User area write protection register	USER_WP	1	[171]	0h
Reserved (note1)	–	1	[170]	–
FW configuration	FW_CONFIG	1	[169]	0h
RPMB Size	RPMB_SIZE_MULT		[168]	4h
Write reliability setting register	WR_REL_SET		[167]	1Fh
Write reliability parameter register	WR_REL_PARAM	1	[166]	15h
Start Sanitize operation	SANITIZE_START	1	[165]	0h
Manually start background operations	BKOPS_START	1	[164]	0h
Enable background operations handshake	BKOPS_EN	1	[163]	0h
H/W reset function	RST_n_FUNCTION	1	[162]	0h
HPI management	HPI_MGMT	1	[161]	0h
Partitioning Support	PARTITIONING_SUPPORT	1	[160]	7h
Max Enhanced Area Size	MAX_ENH_SIZE_MULT	3	[159:157]	228
Partitions attribute	PARTITIONS_ATTRIBUTE	1	[156]	0h
Partitioning Setting	PARTITION_SETTING_COMPLETED	1	[155]	0h
General Purpose Partition Size	GP_SIZE_MULT 4	3	[154:152]	0h
General Purpose Partition Size	GP_SIZE_MULT3	3	[151:149]	0h
General Purpose Partition Size	GP_SIZE_MULT2	3	[148:146]	0h
General Purpose Partition Size	GP_SIZE_MULT1	3	[145:143]	0h
Enhanced User Data Area Size	ENH_SIZE_MULT	3	[142:140]	0h
Enhanced User Data Start Address	ENH_START_ADDR	4	[139:136]	0h
Reserved (note1)	–	1	[135]	–
Bad Block Management mode	SEC_BAD_BLK_MGMNT	1	[134]	0h
Reserved (note1)	–	1	[133]	–
Package Case Temperature is controlled	TCASE_SUPPORT	1	[132]	0h
Periodic Wake-up	PERIODIC_WAKEUP	1	[131]	0h
Program CID/CSD in DDR mode support	PROGRAM_CID_CSD_DDR_SUPPORT	1	[130]	1h
Reserved (note1)	–	2	[129:128]	–
Vendor Specific Fields	VENDOR_SPECIFIC_FIELD	64	[127:64]	–
Native sector size	NATIVE_SECTOR_SIZE	1	[63]	0h
Sector size emulation	USE_NATIVE_SECTOR	1	[62]	0h
Sector size	DATA_SECTOR_SIZE	1	[61]	0h
1st initialization after disabling sector size emulation	INI_TIMEOUT_EMU	1	[60]	0h
Class 6 commands control	CLASS_6_CTRL	1	[59]	0h

Number of addressed group to be Released	DYNCAP_NEEDED	1	[58]	0h
Exception events control	EXCEPTION_EVENTS_CTRL	2	[57:56]	0h
Exception events status	EXCEPTION_EVENTS_STATUS	2	[55:54]	0h
Extended Partitions Attribute	EXT_PARTITIONS_ATTRIBUTE	2	[53:52]	0h
Context configuration	CONTEXT_CONF	15	[51:37]	0h
Packed command status	PACKED_COMMAND_STATUS	1	[36]	0h
Packed command failure index	PACKED_FAILURE_INDEX	1	[35]	0h
Power Off Notification	POWER_OFF_NOTIFICATION	1	[34]	0h
Control to turn the Cache ON/OFF	CACHE_CTRL	1	[33]	0h
Flushing of the cache	FLUSH_CACHE	1	[32]	0h
Control to turn the Barrier ON/OFF	BARRIER_CTRL	1	[31]	0h
Mode config	MODE_CONFIG	1	[30:30]	0h
Mode operation codes	MODE_OPERATION_CODES	1	[29:29]	0h
Reserved (note1)	Reserved	2	[28:27]	-
FFU status	FFU_STATUS	1	[26:26]	0h
Per loading data size	PRE_LOADING_DATA_SIZE	4	[25:22]	0h
Max pre loading data size	MAX_PRE_LOADING_DATA_SIZE	4	[21:18]	00381300h
Product state awareness enablement	PRODUCT_STATE_AWARENESS_ENABLEMENT	1	[17:17]	01h
Secure removal type	SECURE_REMOVAL_TYPE	1	[16:16]	39h
Command Queue Mode enable	CMQ_MODE_EN	1	[15:15]	0h
Reserved (note1)	Reserved	15	[14:0]	-

Note 1. Reserved bits should read as "0."

Note 2. Obsolete values should be don't care.

Note 3. This field is 0 after power-on, H/W reset or software reset, thus selecting the backwards compatibility interface timing for the Device. If the host sets 1 to this field, the Device changes its timing to high speed interface timing. If the host sets value 2 the Device changes its timing to HS200 interface timing, If the host sets HS_TIMING[3:0] to 0x3, the device changes its timing to HS400 interface timing. Refer to JEDEC Standard Specification No.JESD84-B51 for details.

Note 4. It is set to '0' (1 bit data bus) after power up and can be changed by a SWITCH command.

Note 5. * Changed by Firmware release note.

4 Operating Temperature and Voltage Range

Table 4-1. Device Operating Temperature

Parameter	Rating	Unit
Operating temperature (Tcase)	-25 ~ +85	°C

Table 4-2. Device Operating Voltage

Parameter	Symbol	Min	Nom	Max	Unit
Supply voltage (NAND)	VCC	2.7	3.3	3.6	V
Supply voltage (I/O)	VCCQ ¹	2.7	3.3	3.6	V
		1.7	1.8	1.95	V
Supply power-up for 3.3V	tPRUH			35	ms
Supply power-up for 1.8V	tPRUL			25	ms

Note 1.VCCQ (I/O) 3.3 volt range is not supported while operating in HS200 & HS400 modes.

5 Package Outline Information

Table 5-1. FBGA (11.5 x 13 x 0.8mm) Dimension Table

Symbol	Dimension in inch			Dimension in mm		
	Min	Nom	Max	Min	Nom	Max
A	0.024	0.029	0.031	0.62	0.73	0.80
A1	0.006	0.008	0.010	0.15	0.21	0.26
A2	0.018	0.020	0.024	0.46	0.52	0.60
D	0.449	0.453	0.457	11.40	11.50	11.60
E	0.508	0.512	0.516	12.90	13.00	13.10
D1	--	0.256	--	--	6.50	--
E1	--	0.256	--	--	6.50	--
D2	--	0.098	--	--	2.50	--
E2	--	0.098	--	--	2.50	--
SD	--	0.0098	--	--	0.25	--
SE	--	0.0098	--	--	0.25	--
e	--	0.020	--	--	0.50	--
b	0.010	0.012	0.014	0.25	0.30	0.35

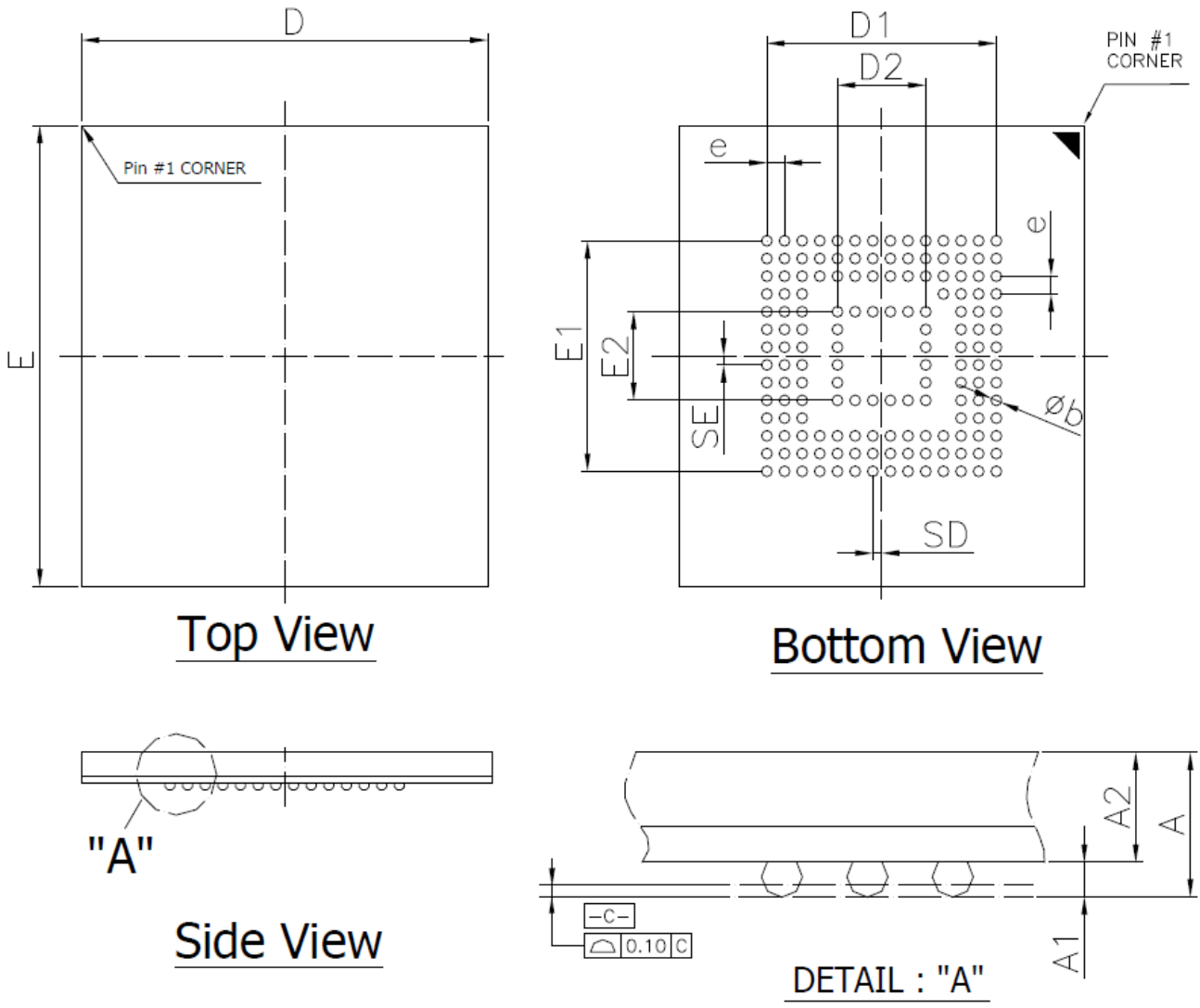

Figure 5-1. Package Outline Drawing Information for FBGA