

SPI NAND Flash Datasheet

Serial Peripheral Interface (SPI)

Model

EM78D044VCM-H

EM78E044VCD-H

SPI NAND Part Numbering Information

Etron SPI NAND Flash devices are categorized in the following diagram based on the features and densities

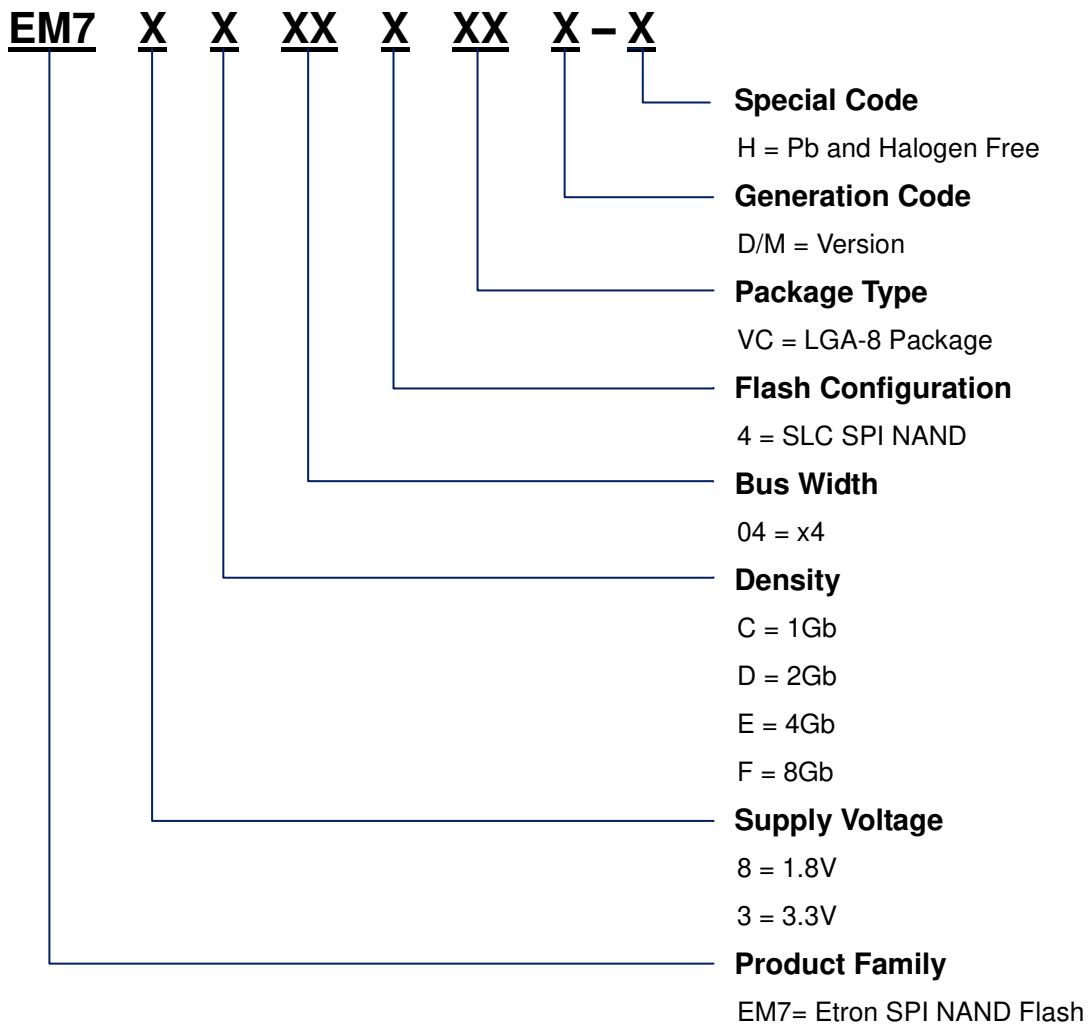

Etron Technology, Inc. reserves the right to change products or specification without notice.

Revision History

| Rev | Date | Comments |
|------------|--------------------|----------------------------|
| 1.00 | March 30, 2022 | Initial release |
| 1.01 | September 01, 2022 | Removed Etron Confidential |

Contents

| | | |
|-----------|--|-----------|
| 1 | Introduction..... | 7 |
| | 1.1 Features..... | 7 |
| | 1.2 General Description..... | 8 |
| | 1.3 Memory Mapping Diagram..... | 9 |
| | 1.4 ECC Protection and Spare Area..... | 10 |
| | 1.5 Pin Configuration..... | 11 |
| 2 | Device Operation..... | 12 |
| | 2.1 SPI Mode..... | 12 |
| | 2.2 Hold Mode..... | 13 |
| | 2.3 Write Protection Mode..... | 14 |
| 3 | Commands Description..... | 15 |
| 4 | Write Operations..... | 16 |
| 5 | Feature Operations..... | 17 |
| 6 | Read Operations..... | 18 |
| | 6.1 Read ID (9FH)..... | 18 |
| | 6.2 Page Read (13H)..... | 19 |
| | 6.3 Read from Cache x1 IO (03H/0BH)..... | 20 |
| | 6.4 Read from Cache x2 IO (3BH)..... | 21 |
| | 6.5 Read from Cache x4 IO (6BH)..... | 22 |
| | 6.6 Read from Cache Dual IO (BBH)..... | 23 |
| | 6.7 Read from Cache Quad IO (EBH)..... | 23 |
| 7 | Program Operations..... | 24 |
| | 7.1 Program Load (PL) (02H)..... | 25 |
| | 7.2 Program Load x4 IO (PL x4) (32H)..... | 25 |
| | 7.3 Program Execute (PE) (10H)..... | 26 |
| 8 | Internal Data Move..... | 27 |
| | 8.1 Program Load Random Data (84H)..... | 27 |
| | 8.2 Program Load Random Data x4 (C4H/34H)..... | 28 |
| | 8.3 Program Load Random Data Quad IO (72H)..... | 29 |
| 9 | Erase Operation- Block Erase (D8H)..... | 30 |
| 10 | Reset Operation - Reset (FFH)..... | 31 |
| 11 | One-Time Programmable (OTP) Function..... | 32 |
| | 11.1 OTP Definition..... | 32 |
| | 11.2 Parameter Page Definition..... | 33 |
| 12 | Block Protection..... | 34 |
| 13 | Status Register..... | 36 |
| 14 | Block Management..... | 37 |
| 15 | Power-On Process..... | 38 |
| 16 | Electrical Characteristics..... | 39 |
| 17 | Package Outline Information..... | 42 |

List of Figures

| | |
|--|----|
| Figure 1-1. Functional Block Diagram | 8 |
| Figure 1-2. Memory Mapping Diagram for EM78D044VCM-H..... | 9 |
| Figure 1-3. Memory Mapping Diagram for EM78E044VCD-H | 9 |
| Figure 1-4. Pin Assignments..... | 11 |
| Figure 2-1. Timing Diagram of SPI Modes..... | 12 |
| Figure 2-2. Hold Condition Diagram | 13 |
| Figure 4-1. Write Enable (06H) Sequence Diagram | 16 |
| Figure 4-2. Write Disable (04H) Sequence Diagram | 16 |
| Figure 5-1. Get Feature (0FH) Sequence Diagram | 17 |
| Figure 5-2. Set Feature (1FH) Sequence Diagram | 17 |
| Figure 6-1. Read ID (9FH) Sequence Diagram | 18 |
| Figure 6-2. Page Read to Cache (13H) Sequence Diagram | 20 |
| Figure 6-3. Read from Cache x1 IO (03H/0BH) Sequence Diagram | 20 |
| Figure 6-4. Read from Cache x2 IO (3BH) Sequence Diagram | 21 |
| Figure 6-5. Read from Cache x4 IO (6BH) Sequence Diagram..... | 22 |
| Figure 6-6. Read from Cache Dual IO (BBH) Sequence Diagram | 23 |
| Figure 6-7. Read from Cache Quad (EBH) Sequence Diagram | 23 |
| Figure 7-1. Program Load (02H) Sequence Diagram | 25 |
| Figure 7-2. Program Load x4 IO (32H) Sequence Diagram..... | 25 |
| Figure 7-3. Program Execute (10H) Sequence Diagram | 26 |
| Figure 8-1. Program Load Random Data (84H) Sequence Diagram | 27 |
| Figure 8-2. Program Load Random Data x4 (C4H/34H) Sequence Diagram | 28 |
| Figure 8-3. Program Load Random Data Quad IO (72H) Sequence Diagram | 29 |
| Figure 9-1. Block Erase (D8H) Sequence Diagram..... | 30 |
| Figure 10-1. Reset (FFH) Sequence Diagram..... | 31 |
| Figure 15-1. Power-On Process | 38 |
| Figure 16-1. Serial Input Timing | 41 |
| Figure 16-2. Serial Output Timing | 41 |
| Figure 16-3. Hold# Timing | 41 |
| Figure 16-4. WP# Timing | 41 |
| Figure 17-1. LGA (8 x 6 x 0.8mm) Package Outline Drawing Information | 43 |

List of Tables

| | |
|---|----|
| Table 1-1. Product Information | 7 |
| Table 1-2. ECC Protection and Spare Area | 10 |
| Table 1-3. Pin Descriptions | 11 |
| Table 3-1. SPI NAND Command Set | 15 |
| Table 5-1. Feature Register Table | 17 |
| Table 6-1. ID Definition Table | 18 |
| Table 6-2. 24-bit address consisting of dummy bits and block/page address bits | 19 |
| Table 6-3. Wrap Bit Definition ⁽²⁾ | 19 |
| Table 11-1. OTP State | 32 |
| Table 11-2. OTP Page Definition | 32 |
| Table 11-3. Parameter Page Data Structure | 33 |
| Table 12-1. Block Protection Bits Table | 35 |
| Table 13-1. Status Register Bit Description | 36 |
| Table 14-1. Valid Block Information | 37 |
| Table 15-1. Power-On Process Parameters | 38 |
| Table 16-1. SPI NAND DC Characteristics | 39 |
| Table 16-2. Capacitance Characteristics | 39 |
| Table 16-3. AC Time Characteristics ($T_A = -40 \sim 85^\circ\text{C}$, $C_L = 10\text{pF}$) | 40 |
| Table 17-1. LGA (8 x 6 x 0.8mm) Dimension Table | 42 |

1 Introduction

1.1 Features

- **Single-Level Cell (SLC) NAND Flash**
- **Operating Voltage Support**
 - VCC: 1.8V (1.7V to 1.98V)
- **Clock Frequency**
 - Up to 100MHz
- **Standard, Dual and Quad SPI**
 - Standard SPI: SCLK, CS#, SI, SO, WP#, HOLD#
 - Dual SPI: SCLK, CS#, SIO0, SIO1, WP#, HOLD#
 - Quad SPI: SCLK, CS#, SIO0, SIO1, SIO2, SIO3
- **ECC Protection**
 - 8bit ECC for each 512bytes + 32bytes
- **Package (Pb Free and Halogen Free)**
 - 8-pin LGA-8 (8 x 6 x 0.8mm)
- **OTP Protection**
 - 64 pages one time programmable
- **Performance (Typical)**
 - Page Program Time: 600us
 - Page Read Time: 70us
 - Block Erase Time: 3ms
- **Operating Current**
 - Read Operation Current: 25mA
 - Program Operation Current: 25mA
 - Erase Operation Current: 30mA
 - 120uA maximum standby current
- **Endurance**
 - P/E cycles: more than 60,000/cycles
- **Data Retention**
 - 10/years
- **Temperature**
 - Operating Temperature: -40°C to +85°C
 - Storage Temperature: -65°C to +150°C

Table 1-1. Product Information

| Part Number | Density | VCC | ECC | Page Size | Block | Device | Package |
|---------------|---------|------|------|----------------|----------|-------------|---------|
| EM78D044VCM-H | 2Gbits | 1.8V | 8bit | 2048+128 Bytes | 64 Pages | 2048 Blocks | LGA-8 |
| EM78E044VCD-H | 4Gbits | 1.8V | 8bit | 2048+128 Bytes | 64 Pages | 4096 Blocks | LGA-8 |

1.2 General Description

SPI (Serial Peripheral Interface) NAND provides a low cost and low pin count solution to alternate SPI-NOR in high density non-volatile memory storage solution for embedded systems.

SPI NAND is a flash memory device with SLC NAND of the standard parallel NAND. The serial electrical interface follows the industry-standard serial peripheral interface. The command sets are similar to SPI-NOR command sets. Some modifications have been made for handling NAND-specific functions. Besides, new features are added to extend applications. The SPI NAND has 8 pin counts in total, including six signal lines plus VCC and GND.

Each block of the serial NAND is subdivided into 64 programmable pages. Each page consists of a data storage region and a spare area. The data storage region is used to store user-programmed data and the spare area is typically used for memory management and error correction functions.

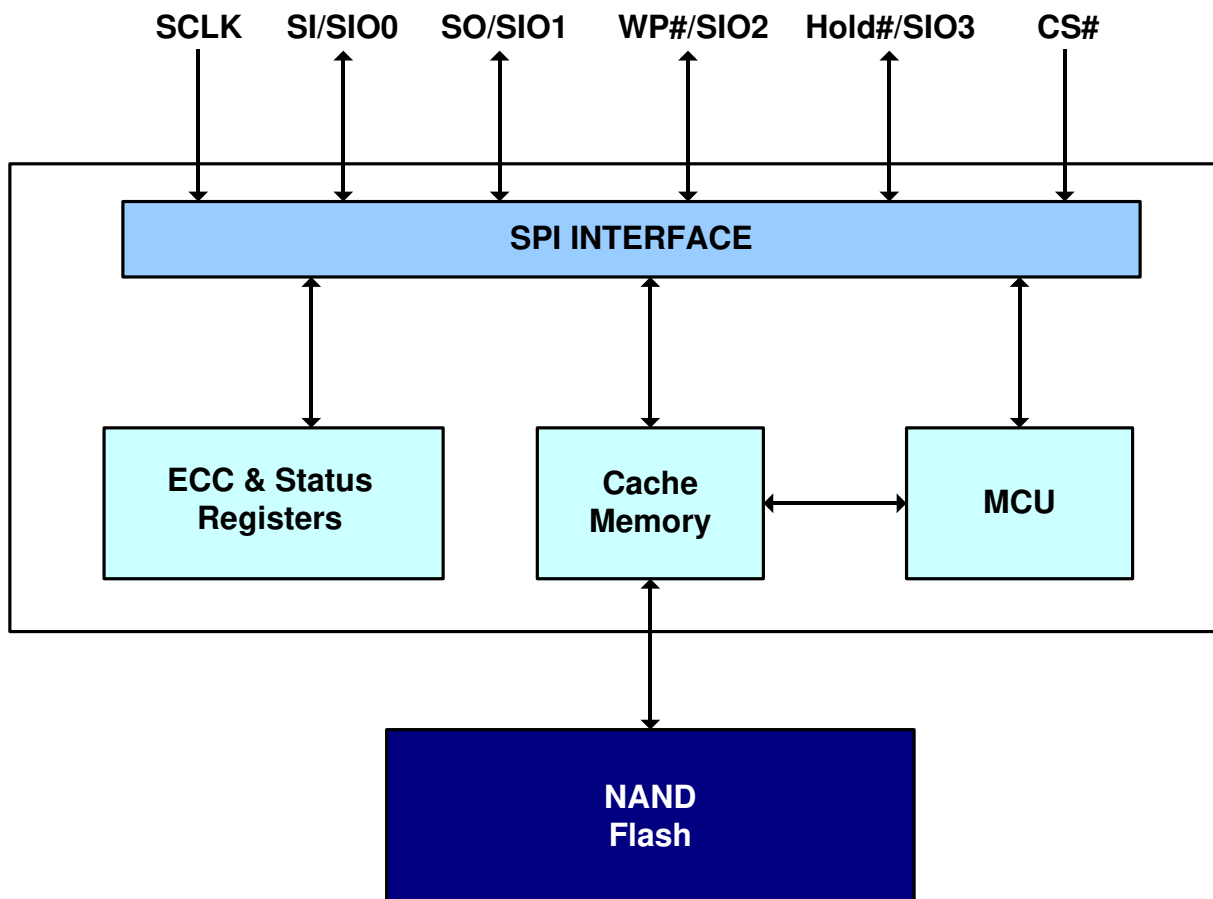

Figure 1-1. Functional Block Diagram

1.3 Memory Mapping Diagram

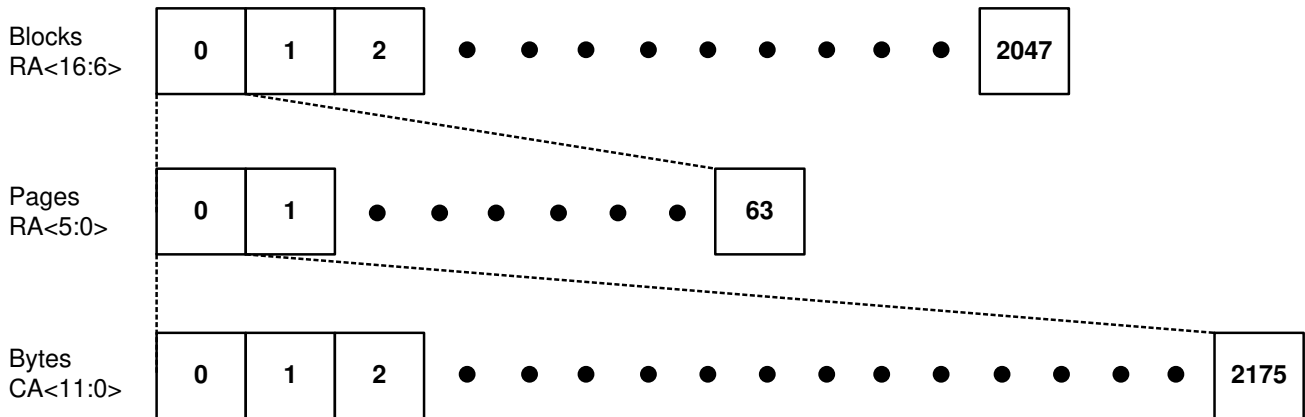

Figure 1-2. Memory Mapping Diagram for EM78D044VCM-H

Notes:

1. CA: Column Address. The 12-bit address is capable of addressing from 0 to 4095 bytes; however, only bytes 0 through 2175 are valid. Bytes 2176 through 4095 of each page are “out of bounds” do not exist in the device, and cannot be addressed.
2. RA: Row Address. RA<5:0> selects a page inside a block, and RA<16:6> selects a block.

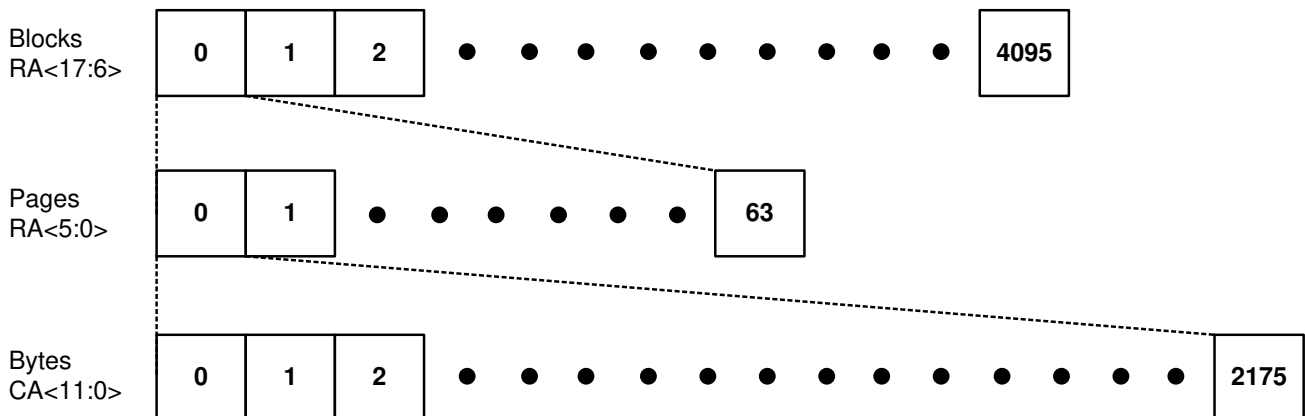

Figure 1-3. Memory Mapping Diagram for EM78E044VCD-H

Notes:

1. CA: Column Address. The 12-bit address is capable of addressing from 0 to 4095 bytes; however, only bytes 0 through 2175 are valid. Bytes 2176 through 4095 of each page are “out of bounds” do not exist in the device, and cannot be addressed.
2. RA: Row Address. RA<5:0> selects a page inside a block, and RA<17:6> selects a block.

1.4 ECC Protection and Spare Area

Table 1-2. ECC Protection and Spare Area

| Start Address | End Address | ECC Protected | Area | Description |
|---------------|-------------|-------------------|---------------|---|
| 000h | 1FFh | Yes | Main Area 01 | Data storage region 01 |
| 200h | 3FFh | Yes | Main Area 02 | Data storage region 02 |
| 400h | 5FFh | Yes | Main Area 03 | Data storage region 03 |
| 600h | 7FFh | Yes | Main Area 04 | Data storage region 04 |
| 800h | 803h | No ⁽²⁾ | Spare Area 01 | Meta data 01-1 |
| 804h | 811h | Yes | | Meta data 01-2 |
| 812h | 815h | No ⁽²⁾ | Spare Area 02 | Meta data 02-1 |
| 816h | 823h | Yes | | Meta data 02-2 |
| 824h | 827h | No ⁽²⁾ | Spare Area 03 | Meta data 03-1 |
| 828h | 835h | Yes | | Meta data 03-2 |
| 836h | 839h | No ⁽²⁾ | Spare Area 04 | Meta data 04-1 |
| 83Ah | 847h | Yes | | Meta data 04-2 |
| 848h | 87Fh | Yes | Spare Area 05 | Internal ECC parity area ⁽¹⁾ |

Notes:

1. When ECC is enabled, the internal ECC parity area only can be read, and the data is 'FF'.
2. The 1st to 4th bytes in the meta data are unprotected by ECC.

1.5 Pin Configuration

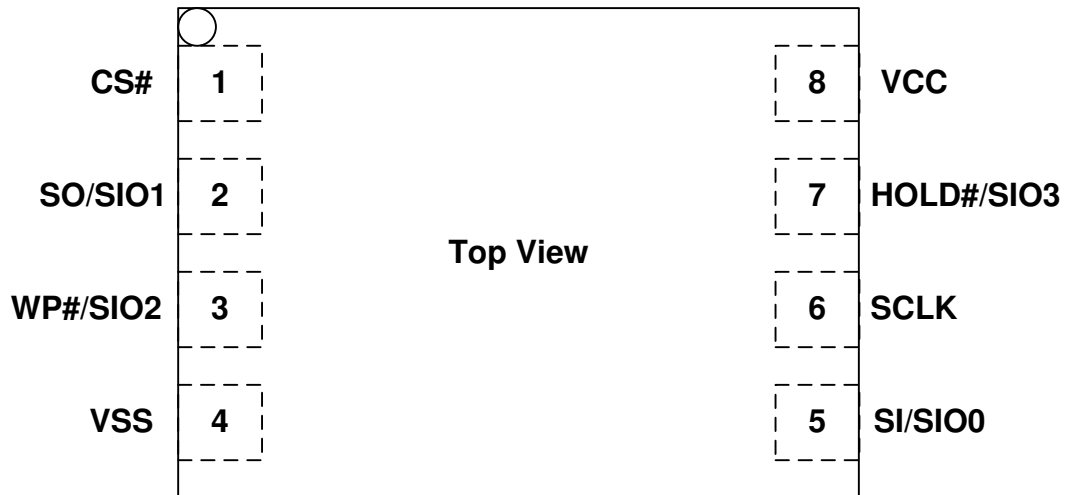

Figure 1-4. Pin Assignments

Table 1-3. Pin Descriptions

| Pin Name | Type | Description |
|------------|--------|--------------------------------------|
| CS# | Input | Chip Select |
| SCLK | Input | Serial Clock |
| SI/SIO0 | I/O | Serial Data Input / Serial Data IO0 |
| SO/SIO1 | I/O | Serial Data Output / Serial Data IO1 |
| WP#/SIO2 | I/O | Write Protect / Serial Data IO2 |
| Hold#/SIO3 | I/O | Hold / Serial Data IO3 |
| VCC | Supply | Power Supply |
| VSS | Ground | Ground |

2 Device Operation

2.1 SPI Mode

SPI NAND supports two SPI modes:

- CPOL = 0, CPHA = 0 (Mode 0)
- CPOL = 1, CPHA = 1 (Mode 3)

Input data is latched in on the rising edge of SCLK and output data is available on the falling edge of SCLK for both mode 0 and mode 3. The timing diagrams shown in this data sheet are mode 0.

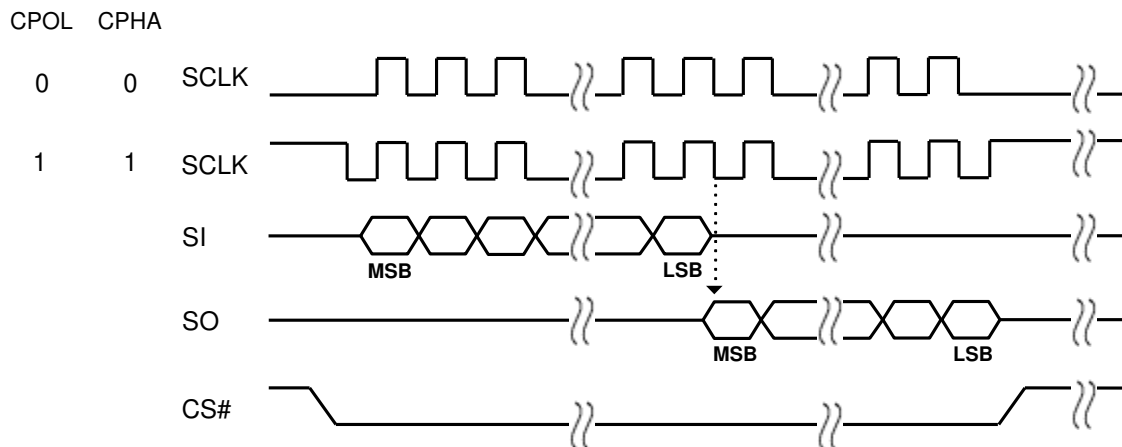

Figure 2-1. Timing Diagram of SPI Modes

Note:

1. SCLK provides interface timing for SPI NAND. Address, data and commands are latched on the rising edge of SCLK. Data is placed on SO at the falling edge of SCLK.
2. When CS# is 0, the device is placed in active mode. When CS# goes 1, the device is placed in inactive mode and SO is High-Z.

2.1.1 Standard SPI

Standard serial peripheral interface on four signals bus: System Clock (SCLK), Chip Select (CS#), Serial Data In (SI) and Serial Data Out (SO).

2.1.2 Dual SPI

The device supports dual SPI operation with x2 and dual IO commands. These commands allow data to be transferred to or from the device at two times of rates of Standard SPI operation. The SI and the SO become bi-directional I/O pins: SIO0 and SIO1.

2.1.3 Quad SPI

The device supports the x4 and Quad commands operation. These commands allow data to be transferred to or from the device at four times of rates of Standard SPI operation. The SI and the SO become bi-directional I/O pins: SIO0 and SIO1. The WP# and the HOLD# pins become SIO2 and SIO3. Once use the Quad SPI Mode, the Quad Enable (QE) bit of OTP register (B0[0]) must be set to 1^[1].

Note:

[1] Reference the Table 3-1 and the Table 5-1.

2.2 Hold Mode

The HOLD# signal goes low to stop any serial communications with the device, but doesn't stop the operation of writing status register, programming or erasing in progress.

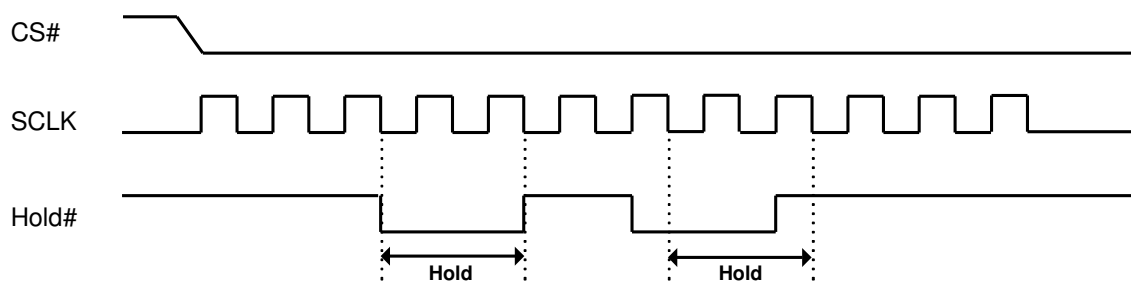

Figure 2-2. Hold Condition Diagram

Note:

Hold mode starts at the falling edge of HOLD# provided SCLK is also LOW. When SCLK is HIGH and HOLD# goes LOW, hold mode begins after the next falling edge of SCLK.

2.3 Write Protection Mode

Write protect (WP#) provides hardware protection mode. The WP# prevents the block lock bits (BP0, BP1, and BP2) from being overwritten. If the BRWD bit is set to 1 and WP# is LOW, the block protect bits cannot be altered.

3 Commands Description

Table 3-1. SPI NAND Command Set

| Command | Op Code | 2 nd Byte | 3 rd Byte | 4 th Byte | 5 th Byte | 6 th Byte | N th Byte |
|----------------------------------|------------------------|----------------------|----------------------|----------------------|----------------------|----------------------|----------------------|
| Write Disable | 04H | - | - | - | - | - | - |
| Write Enable | 06H | - | - | - | - | - | - |
| Block Erase (Block size) | D8H ⁽³⁾ | A23-A16 | A15-A8 | A7-A0 | - | - | - |
| Program Load | 02H | A15-A8 | A7-A0 | D7-D0 | Next data | Next data | - |
| Program Load x4 IO | 32H | A15-A8 | A7-A0 | (D7-D0)x4 | Next data | Next data | - |
| Program Execute | 10H ⁽³⁾ | A23-A16 | A15-A8 | A7-A0 | - | - | - |
| Program Load Random Data | 84H ⁽¹⁾ | A15-A8 | A7-A0 | D7-D0 | Next data | Next data | - |
| Program Load Random Data x4 IO | C4H/34H ⁽¹⁾ | A15-A8 | A7-A0 | (D7-D0)x4 | Next data | Next data | - |
| Program Load Random Data Quad IO | 72H ⁽¹⁾⁽²⁾ | A15-A0 | (D7-D0)x4 | Next data | Next data | Next data | - |
| Page Read (to Cache) | 13H ⁽³⁾ | A23-A16 | A15-A8 | A7-A0 | - | - | - |
| Read from Cache x1 IO | 03H/0BH | A15-A8 | A7-A0 | Dummy | D7-D0 | Next data | Wrap |
| Read from Cache x2 IO | 3BH | A15-A8 | A7-A0 | Dummy | (D7-D0)x2 | Next data | Wrap |
| Read from Cache x4 IO | 6BH | A15-A8 | A7-A0 | Dummy | (D7-D0)x4 | Next data | Wrap |
| Read from Cache Dual IO | BBH | A15-A0 | Dummy | (D7-D0)x2 | Next data | Next data | Wrap |
| Read from Cache Quad IO | EBH ⁽²⁾ | A15-A0 | Dummy | (D7-D0)x4 | Next data | Next data | Wrap |
| Read ID | 9FH ⁽³⁾ | A7-A0 | MID | DID | Wrap | Wrap | Wrap |
| Reset | FFH | - | - | - | - | - | - |
| Get Feature | 0FH ⁽³⁾ | A7-A0 | D7-D0 | - | - | - | - |
| Set Feature | 1FH ⁽³⁾ | A7-A0 | D7-D0 | - | - | - | - |

Note:

1. These commands are only available in Internal Data Move operation.
2. Quad Enable (QE) bit needs to be set to 1 when these commands are issued.
3. If QE = 1, do not make HOLD#/SIO3 = 0, when these commands are issued.

4 Write Operations

The WRITE ENABLE (WREN, 06H) command is for setting the Write Enable Latch (WEL) bit. The WRITE DISABLE (WRDI, 04H) command is for clearing the WEL bit.

As with any command that changes the memory contents, the WRITE ENABLE command must be executed at first in order to set the WEL bit to 1. For more information, please refer to the Page Read operation sequence, PAGE PROGRAM operation sequence, Internal Data Move operation sequence, BLOCK ERASE operation sequence and OTP operation sequence.

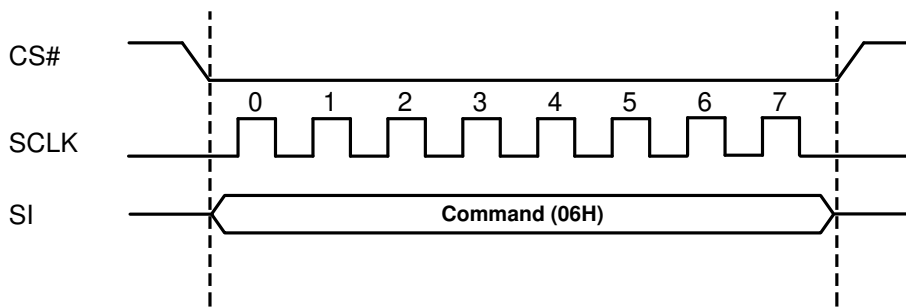

Figure 4-1. Write Enable (06H) Sequence Diagram

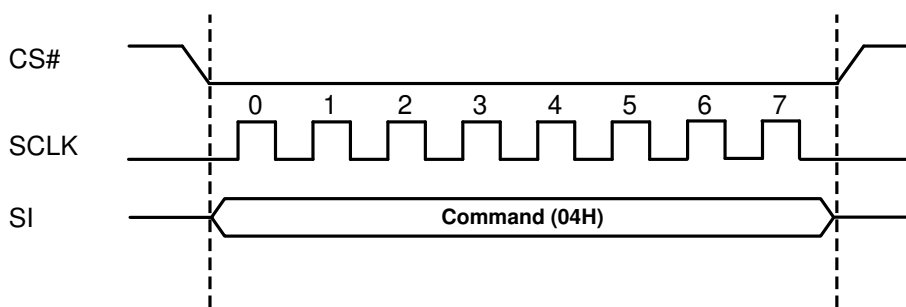

Figure 4-2. Write Disable (04H) Sequence Diagram

5 Feature Operations

The GET FEATURE (0FH) and SET FEATURE (1FH) commands are used to monitor the device status and alter the device behavior.

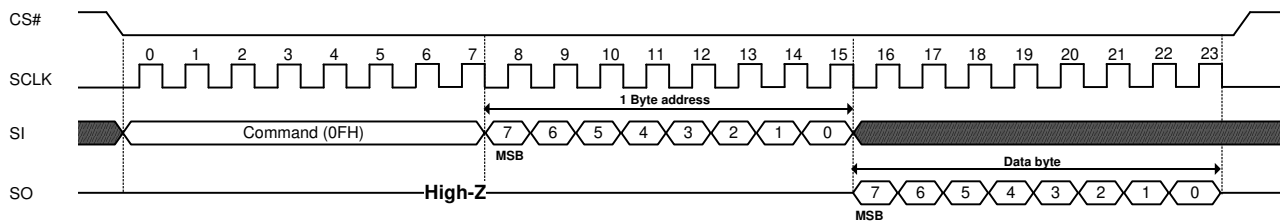
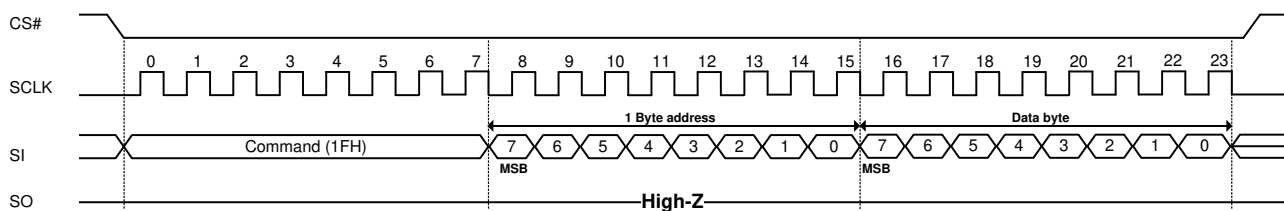

Figure 5-1. Get Feature (0FH) Sequence Diagram



Notes : If the status OIP = 1, the 'Set Feature (1FH)' command will be disable

Figure 5-2. Set Feature (1FH) Sequence Diagram

Table 5-1. Feature Register Table

| Register | Address | Data Bits | | | | | | | |
|------------|---------|------------------------|-------------------------|----------------------|-------------------------|-----------------------|-----------------------|----------------------|---------------------|
| | | 7 | 6 | 5 | 4 | 3 | 2 | 1 | 0 |
| Block Lock | A0H | BRWD ^(R/W) | Reserved | BP2 ^(R/W) | BP1 ^(R/W) | BP0 ^(R/W) | INV ^(R/W) | CMP ^(R/W) | Reserved |
| OTP | B0H | OTP_PRT ^(R) | OTP_EN ^(R/W) | Reserved | ECC_EN ^(R/W) | Reserved | Reserved | Reserved | QE ^(R/W) |
| Status | C0H | Reserved | Reserved | ECCS1 ^(R) | ECCS0 ^(R) | P_FAIL ^(R) | E_FAIL ^(R) | WEL ^(R) | OIP ^(R) |

Note:

1. (R/W) : This bit can be read & programmed.
2. (R) : This bit only can be read.
3. Reserved : Default value 0h.
4. The ECC status of register C0H will be cleared when ECC is disabled.
5. The default value of feature register is A0H=0x38 , B0H=0x10 , C0H=0x00.

6 Read Operations

6.1 Read ID (9FH)

The Read ID command is used to identify the SPI NAND. The Read ID command outputs the manufacturer ID with address byte 00H and outputs the device ID when address byte is 01H. If the SCLK keeps outputting, the SO will repeatedly outputs the MID/DID.

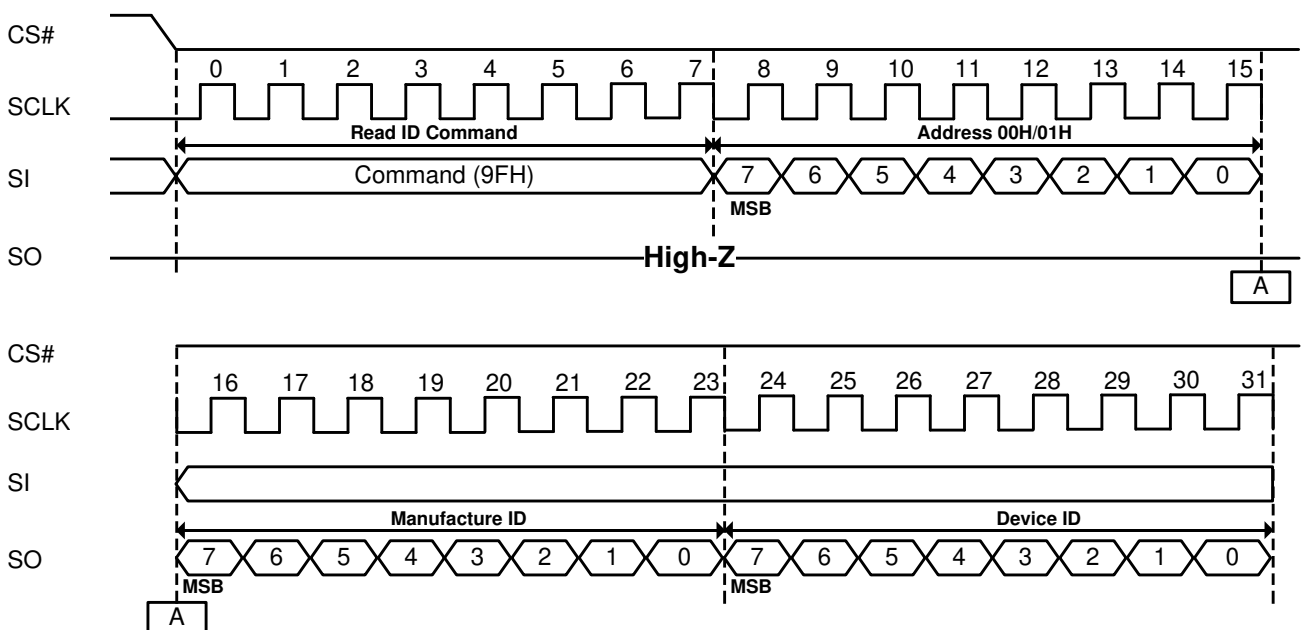

Figure 6-1. Read ID (9FH) Sequence Diagram

Table 6-1. ID Definition Table

| Address Byte | Value | R/W | Description |
|--------------|-------|-----|--------------------------|
| 00h | D5h | R | Manufacturer ID: Etron |
| 01h | 8Eh | R | Device ID: EM78D044VCM-H |
| 01h | 8Fh | R | Device ID: EM78E044VCD-H |

6.2 Page Read (13H)

The Page Read (13H) command transfers the data from the NAND array to the cache memory. The command sequence is described as follows:

- I. 13H (Page Read to Cache)
- II. 0FH (GET FEATURE command to read the status)
- III. Read from Cache memory
 - 03H or 0BH (Read from Cache x1 IO) / 3BH (Read from Cache x2 IO) / 6BH (Read from Cache x4 IO)
 - BBH (Read from Cache Dual IO) / EBH (Read from Cache Quad IO)

The Page Read command requires a 24-bit address consisting of dummy bits and block/page address bits, see the Table 6-2 definition. After the block/page addresses are registered, the device starts transferring from the main array to the cache register, and is busy for tRD time. During the busy time, the GET FEATURE command needs to be issued to monitor the status of Page Read. After finishing the Page Read successfully, the OIP bit in status register (C0H) will be set to 0. Then the Read from Cache command can be issued in order to read the data out of the cache.

The Read from Cache command requires 16 bits of column address which consists of wrap bits and column address bits, see the Table 6-3 definition. The number of bits of column address depends on the page size in different flash.

Table 6-2. 24-bit address consisting of dummy bits and block/page address bits.

| Row Address | 24-Bits Address | |
|-------------|-----------------|--|
| Block | Dummy Bits | Page/Block address bits ⁽¹⁾ |
| 4096 | RA<23:18> | RA<17:0> |
| 2048 | RA<23:17> | RA<16:0> |

Table 6-3. Wrap Bit Definition⁽²⁾

| Wrap <2> | Wrap <1> | Wrap <0> | Wrap Length (Byte) |
|----------|----------|----------|--------------------|
| 0 | 0 | X | 2176 |
| 0 | 1 | X | 2048 |
| 1 | 0 | X | 64 |
| 1 | 1 | X | 16 |

Note:

1. Please refer the Figure 1-2 / Figure 1-3.
2. Wrap bit has 3 bits and located at the first 3 bits in 16-bits column address.

6.2.1 Page Read to Cache (13H)

The waveform of Page Read to Cache (13H) is shown as follows:

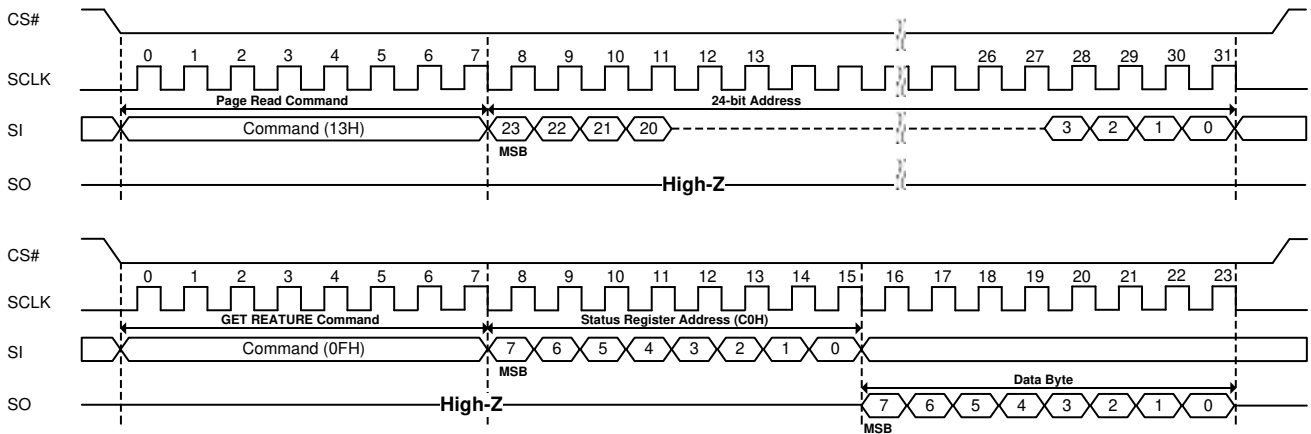

Figure 6-2. Page Read to Cache (13H) Sequence Diagram

6.3 Read from Cache x1 IO (03H/0BH)

The Read from Cache x1 IO (03H/0BH) consists of an OP code followed by 16-bit column address. The column address is composed of wrap bits and column address bits. Refer the Read from Cache x1 IO sequence diagram as follows:

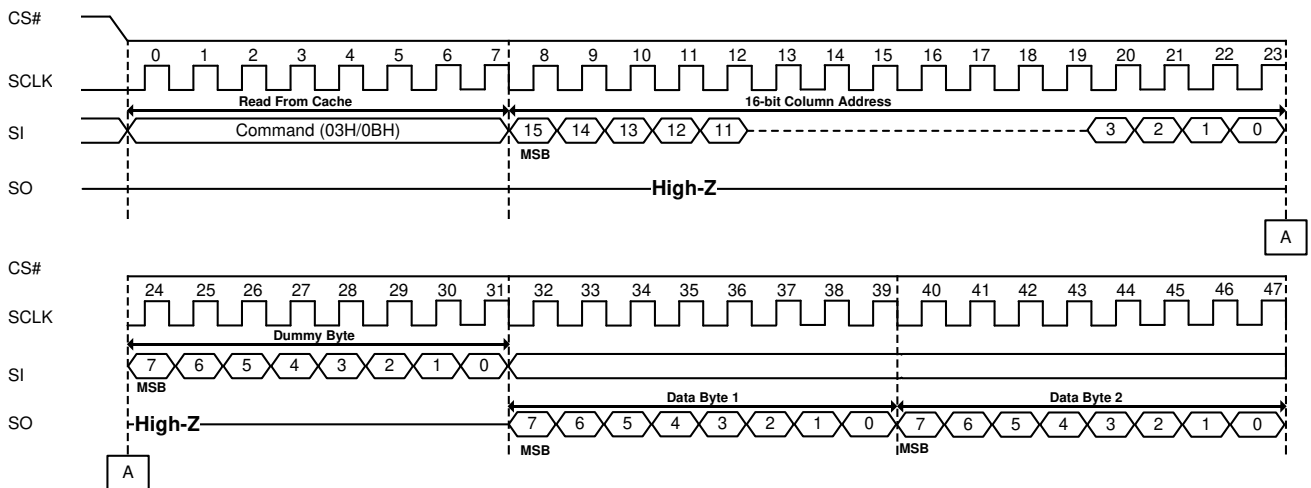

Figure 6-3. Read from Cache x1 IO (03H/0BH) Sequence Diagram

6.4 Read from Cache x2 IO (3BH)

The Read from Cache x2 IO (3BH) command is similar to the Read from Cache x1 IO (03H/0BH) but the command uses two pins to output data. The data output pins include the SI (SIO0) and the SO (SIO1). The Read from Cache x2 IO (3BH) sequence diagram is shown as follows:

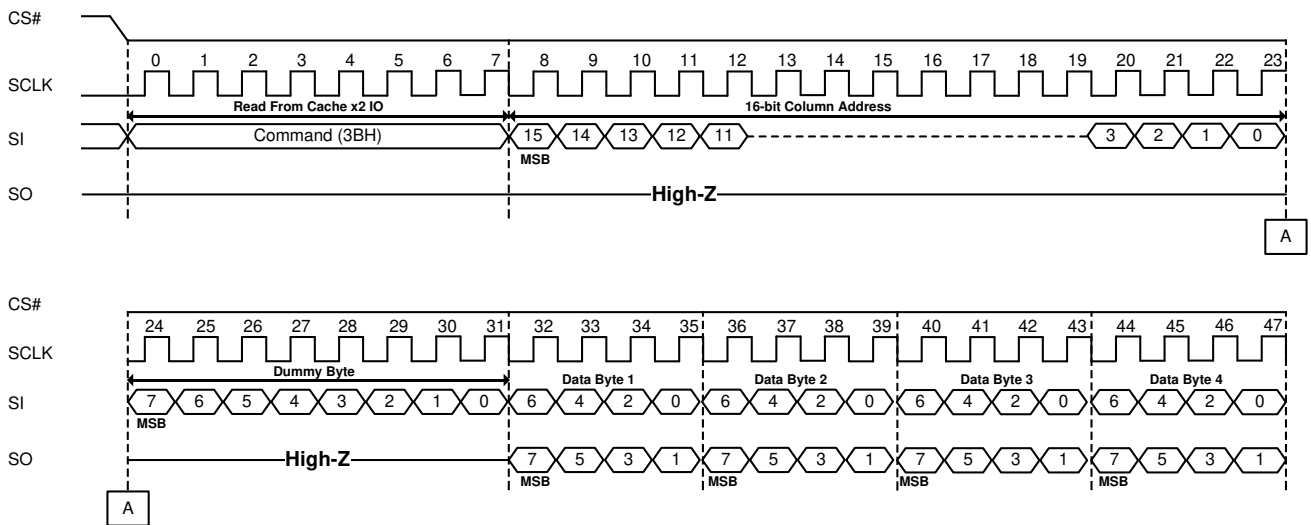

Figure 6-4. Read from Cache x2 IO (3BH) Sequence Diagram

6.5 Read from Cache x4 IO (6BH)

The Read from Cache x4 IO (6BH) command is similar to the Read from Cache x1 IO (03H/0BH) and the Read from Cache x2 IO (3BH) but the command uses four pins to output data. The four pins include the SI (SIO0), SO (SIO1), WP# (SIO2) and HOLD# (SIO3). The Read from Cache x4 IO (6BH) sequence diagram is shown as follows:

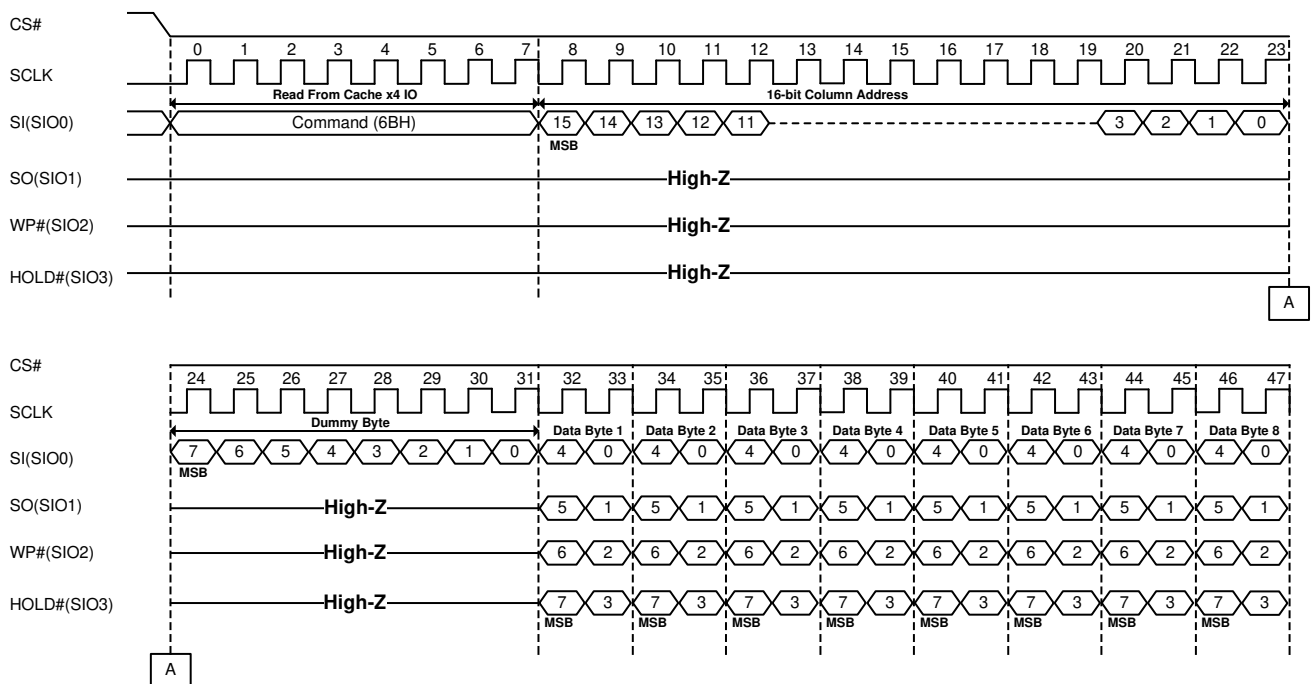

Figure 6-5. Read from Cache x4 IO (6BH) Sequence Diagram

6.6 Read from Cache Dual IO (BBH)

The Read from Cache Dual IO command (BBH) is similar to the Read from Cache x2 IO command (3BH) and uses both of SI (SIO0) and SO (SIO1) as input bin. Each bit in 16-bit column address and the followed dummy byte will be latched in during the falling edge of SCLK, then the cache contents will be shifted out 2-bit in a clock cycle through the SI (SIO0) and the SO (SIO1).

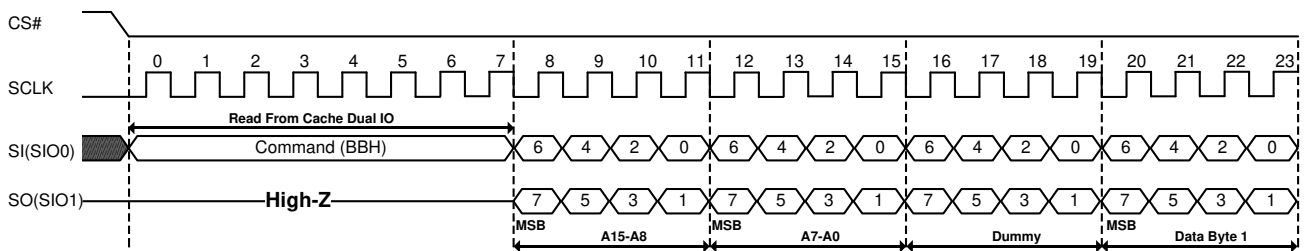

Figure 6-6. Read from Cache Dual IO (BBH) Sequence Diagram

6.7 Read from Cache Quad IO (EBH)

The Read from Cache Quad IO (EBH) command is similar to the Read from Cache x4 IO (6BH) command and has 4 input pins which are SI (SIO0), SO (SIO1), WP# (SIO2) and HOLD# (SIO3). Each bit in 16-bit column address and the followed dummy byte will be latched in during the raising edge of SCLK through these four input pins, and then the cache contents will be shifted out 4-bit in a clock cycle through SI (SIO0), SO (SIO1), WP# (SIO2) and HOLD# (SIO3). The Quad Enable bit (QE) of OTP register (B0[0]) must be set to enable the Read from Cache Quad IO (EBH) command.

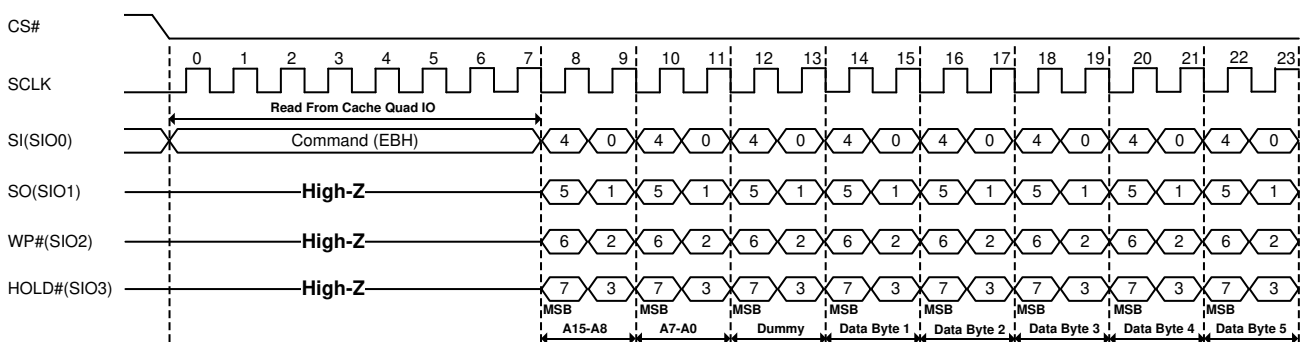

Figure 6-7. Read from Cache Quad (EBH) Sequence Diagram

7 Program Operations

The PAGE PROGRAM sequence transfers the data from the host to NAND flash array through cache memory. The operation sequence programs the first byte to last byte of data within a page. If page size is not enough, those additional bytes will be ignored by the cache memory. The PAGE PROGRAM sequence is as follows:

- I. 06H (WRITE ENABLE when WEL bit is 0)
- II. PROGRAM LOAD
 - 02H (PROGRAM LOAD) / 32H (PROGRAM LOAD x4)
- III. 10H (PROGRAM EXECUTE)
- IV. 0FH (GET FEATURE command to read the status)

At first, the WRITE ENABLE (06H) command is used to set the Write Enable Latch (WEL) bit. The Write Enable Latch (WEL) bit must be set prior to issuing a program execute (10h). The PROGRAM LOAD (02H/32H) command is issued then and the PROGRAM LOAD command can only be issued one time in a PAGE PROGRAM sequence. Secondly, the PROGRAM EXECUTE (10H) command is issued to program the data into the page. During the busy time, the GET FEATURE command needs to be issued to monitor the status of PAGE PROGRAM. After finishing the PAGE PROGRAM successfully, the OIP and WEL bit in status register (C0H) will be set to 0.

7.1 Program Load (PL) (02H)

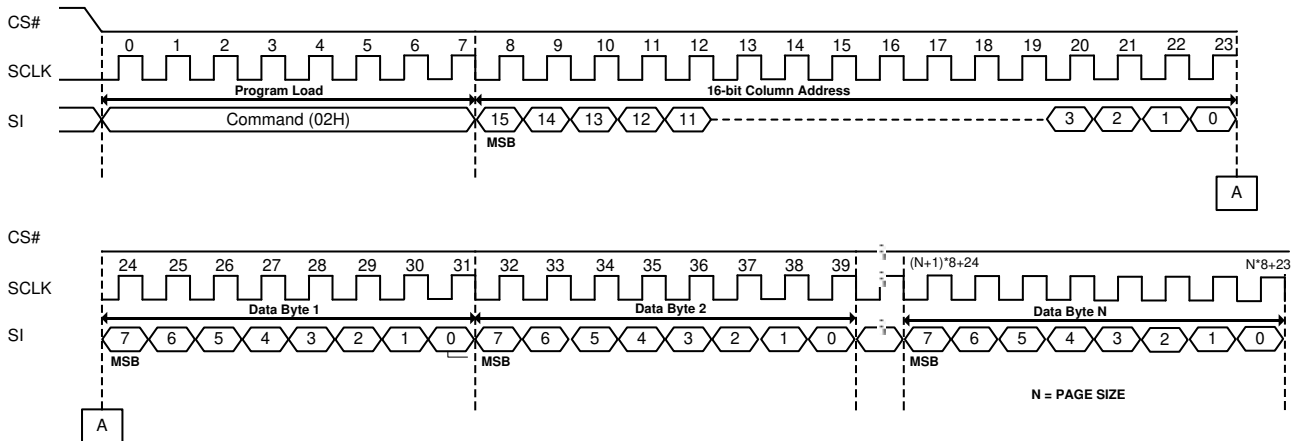

Figure 7-1. Program Load (02H) Sequence Diagram

7.2 Program Load x4 IO (PL x4) (32H)

The PROGRAM LOAD x4 IO (32H) command is similar to the PROGRAM LOAD (02H) command and uses four input pins to transfer data in. The four input pins are SI (SIO0), SO (SIO1), WP# (SIO2) and HOLD# (SIO3). The Quad Enable bit (QE) of OTP register (B0[0]) must be set to enable the PROGRAM LOAD x4 IO (32H) command. The command sequence is shown as follows:

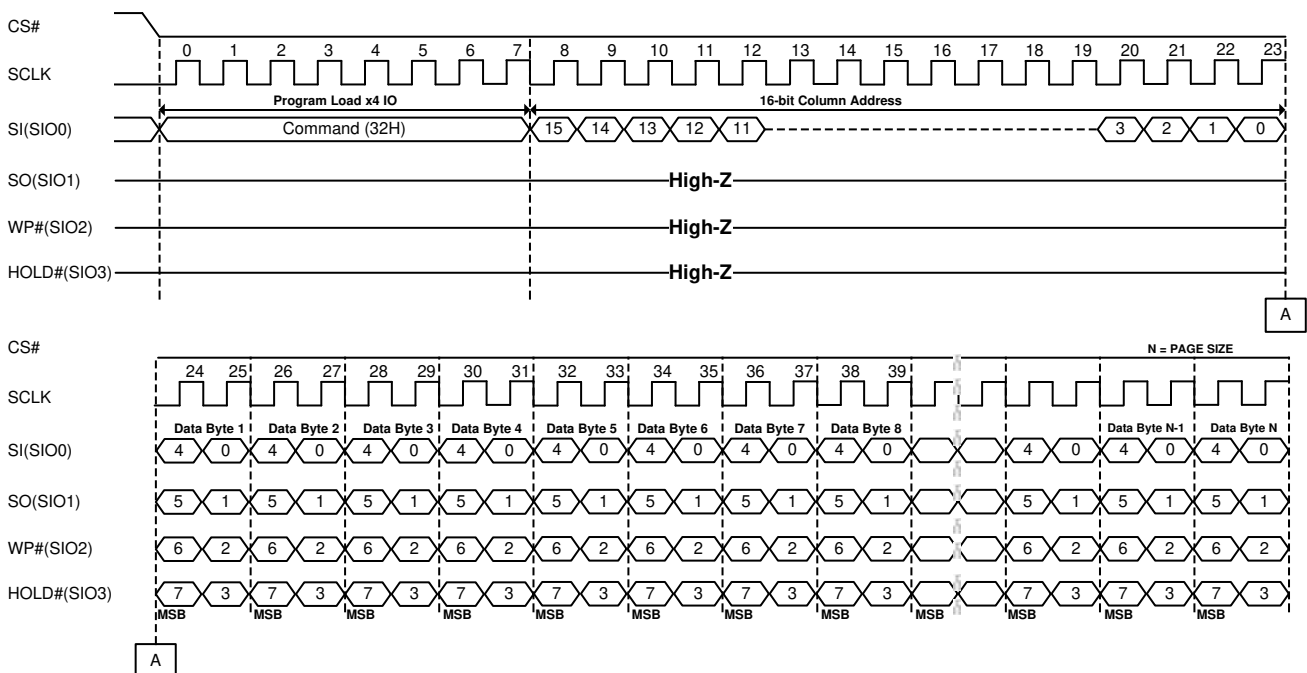

Figure 7-2. Program Load x4 IO (32H) Sequence Diagram

7.3 Program Execute (PE) (10H)

PROGRAM EXECUTE (10H) command must be issued after the data is loaded and the WEL bit is set to HIGH. The PROGRAM EXECUTE (10H) command will transfer data from the cache to the main array. The PROGRAM EXECUTE (10H) consists of an 8-bit Op code, followed by a 24-bit address which including dummy bits and page/block address. This operation needs to wait the busy time. The OIP bit in status register (C0H) will be HIGH until controller finishes the program. The P_FAIL bit in status register (C0H) will be set HIGH if program fail.

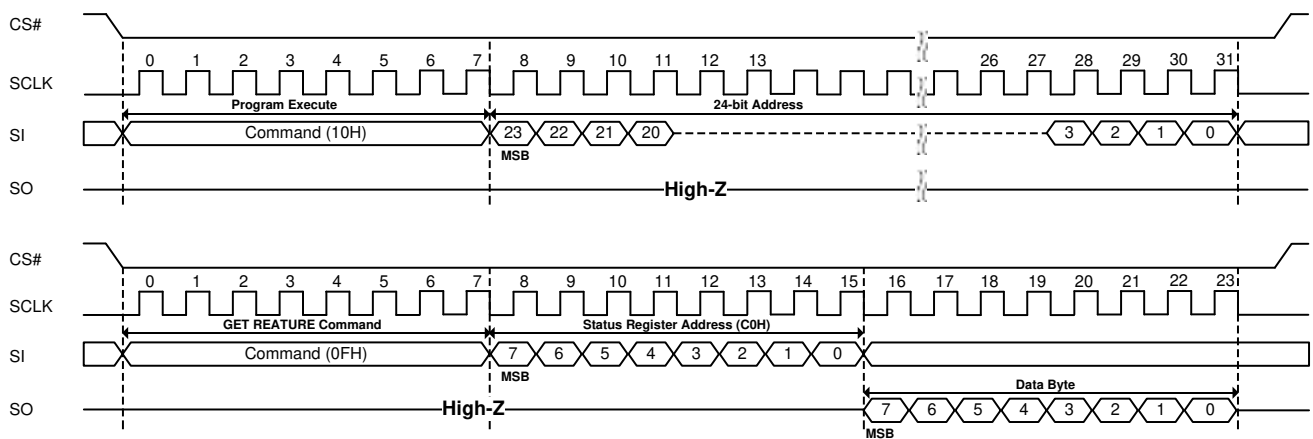

Figure 7-3. Program Execute (10H) Sequence Diagram

8 Internal Data Move

The Internal Data Move sequence programs or replaces data in a page with existing data. The Internal Data Move operation sequence is as follows:

- I. 13H (Page Read to cache)
 - II. 0FH (GET FEATURE command to read the status).
 - III. Optional 84H/C4H/34H/72H (PROGRAM LOAD RANDOM DATA. The command of Program load random data can be operated several times in this step.)
 - IV. 06H (WRITE ENABLE)
 - V. 10H (PROGRAM EXECUTE)
 - VI. 0FH (GET FEATURE command to read the status)
- 84H/C4H/34H/72H commands are only available in Internal Data Move operation.

8.1 Program Load Random Data (84H)

Program Load Random Data (84H) command consists of an OP code, followed by 16 bit column address which includes dummy bits and column address bits. This command can only be used in Internal Data Move sequence.

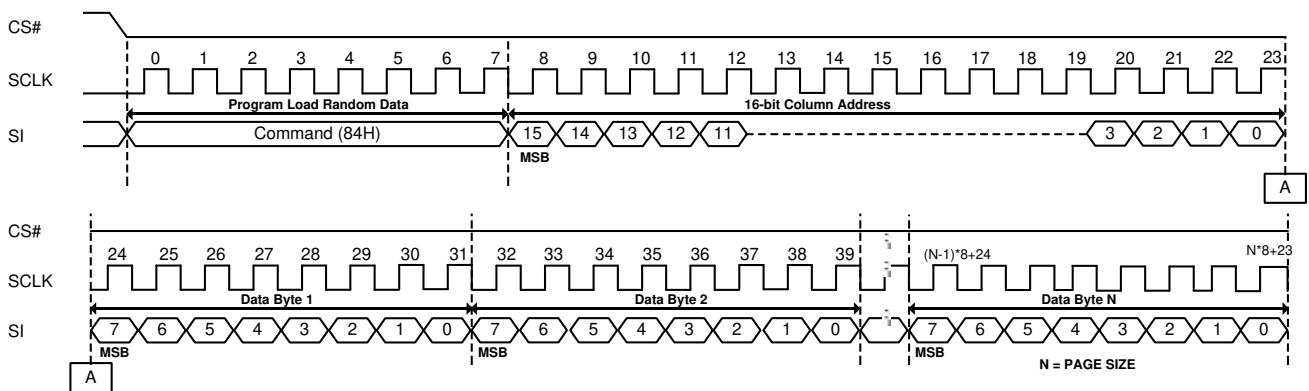

Figure 8-1. Program Load Random Data (84H) Sequence Diagram

8.2 Program Load Random Data x4 (C4H/34H)

The Program Load Random Data x4 (C4H/34H) command is similar to the Program Load Random Data Command (84H) and has four input pins. The four input pins are SI(SIO0), SO(SIO1), WP#(SIO2) and HOLD#(SIO3). The Quad Enable bit needs to be set before the Program Load Random Data x4 command be used. The command is only available during the Internal Data Move sequence.

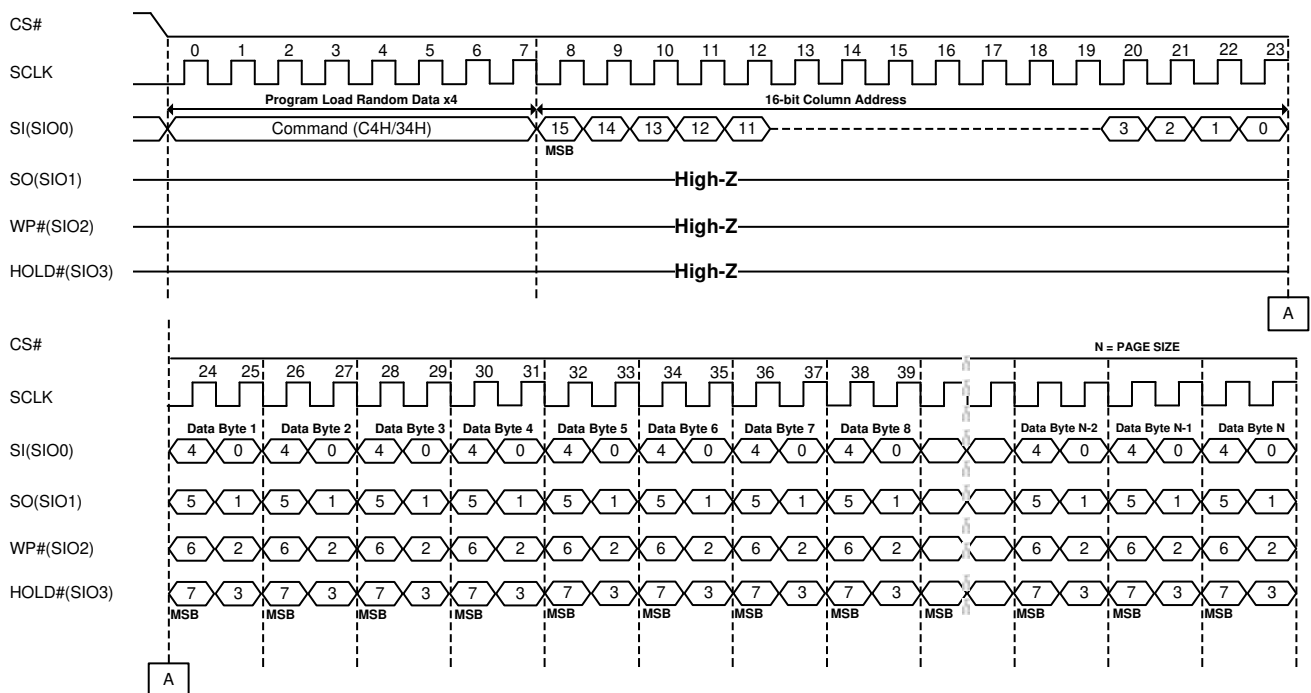

Figure 8-2. Program Load Random Data x4 (C4H/34H) Sequence Diagram

8.3 Program Load Random Data Quad IO (72H)

The Program Load Random Data Quad IO (72H) is similar to the Program Load Random Data x4 (C4H/34H) command and has 4 input pins: SI(SIO0), SO(SIO1), WP#(SIO2) and HOLD#(SIO3). The Quad Enable (QE) bit in feature register (B0[0]) needs to be set to 1 for the Program Load Random Data Quad IO command. This command is only available during Internal Data Move sequence.

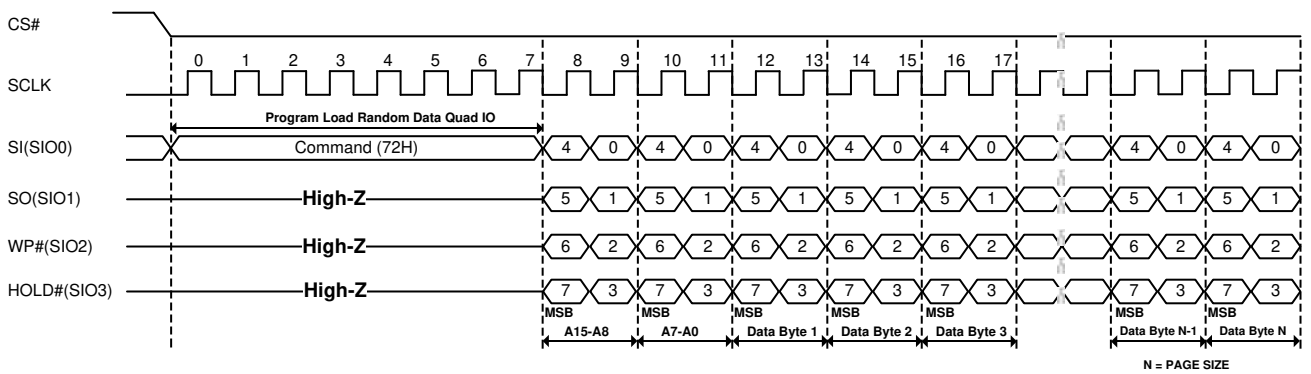

Figure 8-3. Program Load Random Data Quad IO (72H) Sequence Diagram

9 Erase Operation- Block Erase (D8H)

The BLOCK ERASE (D8H) command is used to erase at block level. The command sequence for BLOCK ERASE operation is as follows:

- I. 06H (WRITE ENABLE command)
- II. D8H (BLOCK ERASE command)
- III. 0FH (GET FEATURE command to read the status register)

Erase Operation sequence starts from a WRITE ENABLE (06H) command to set WEL bit to 1. After executing the WRITE ENABLE command, BLOCK ERASE (D8H) command can be issued. BLOCK ERASE (D8H) requires a 24-bit address which consists of dummy bits and row address (page address in row address will be ignored automatically). Issue the GET FEATURE (0FH) command to monitor the erase operation after issuing the BLOCK ERASE. The E_FAIL bit in status register can reflect whether the block be erased successfully or not.

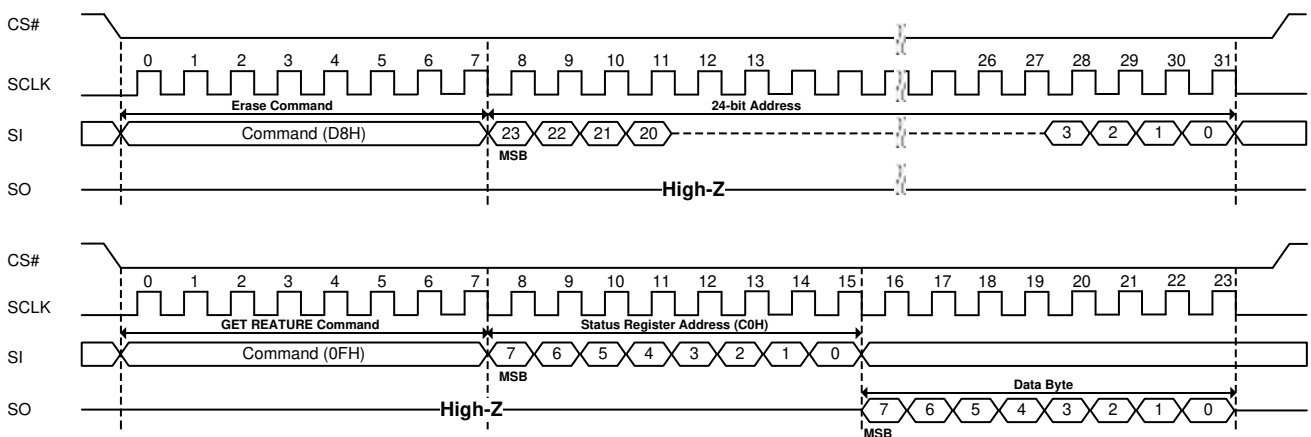

Figure 9-1. Block Erase (D8H) Sequence Diagram

10 Reset Operation - Reset (FFH)

The RESET (FFH) command stops all operations. For example, the RESET command can stop the previous operation and the pending operations during a cache program or a cache read command.

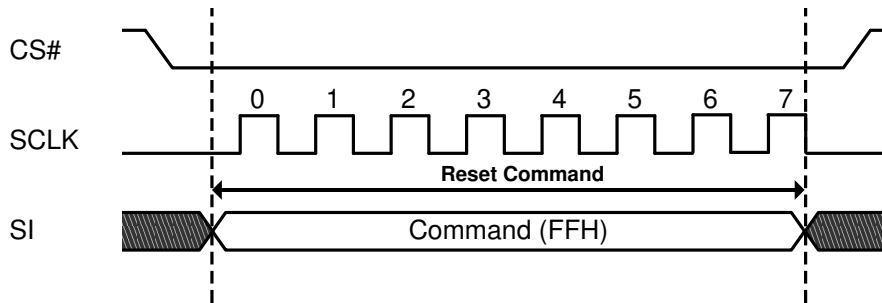

Figure 10-1. Reset (FFH) Sequence Diagram

11 One-Time Programmable (OTP) Function

11.1 OTP Definition

The serial device offers a protected, OTP area. 64 full pages are available on the device. Users can use the OTP area any way they want, like programming serial numbers, or other data, for permanent storage. When delivered from factory, feature bit OTP_PRT is 0.

Table 11-1. OTP State

| OTP_PRT | OTP_EN | State |
|---------|--------|---|
| X | 0 | Normal operation. Cannot access the OTP region. |
| 0 | 1 | Access OTP region. PAGE READ and PAGE PROGRAM are allowed. |
| 1 | 1 | The OTP_PRT has two situations when the device power on, 1. OTP_PRT is 0 when the device power on: User can use SET FEATURE command to set the OTP_PRT and OTP_EN bit to 1, and then issue PROGRAM EXECUTE (10H) to lock OTP region. Once the OTP region was locked, the OTP_PRT will permanently be 1. 2. OTP_PRT is 1 when the device power on: user can only read the OTP region data. |

Table 11-2. OTP Page Definition

| Page Address | Page Name | Description | Data Length | Notes |
|--------------|--------------------------------|---|---------------|-------|
| 00h | Parameter Page OTP Page [0] | Factory Programmed , Read Only | 256 Bytes * 4 | |
| 01h ~ 3Fh | OTP Page [1:63] | Read & Program when OTP_PRT=0 Read Only when OTP_PRT=1 | 2,176 Bytes | |

How to access to OTP region:

1. Issue the GET FEATUTE command (0FH).
2. Set Feature bit OTP_EN.
3. Issue the PAGE READ command or PAGE PROGRAM command. The PAGE PROGRAM command can be allowed only when OTP_PRT is 0. The PAGE READ command will automatically be ignored if OTP_PRT is 1.

How to protect OTP region:

Only when the following steps are completed, the OTP_PRT will be set to 1.

1. Issue the SET FEATURE (1FH) command.
2. Set feature bit OTP_EN and OTP_PRT.
3. 06H (WRITE ENABLE)
4. Issue the PROGRAM EXECUTE (10H) command.
5. Issue the GET FEATURE (0FH) command to wait the device goes to ready state from busy.

11.2 Parameter Page Definition

Table 11-3. Parameter Page Data Structure

| Parameter Page Data Structure | | | |
|-------------------------------|---|---------|---|
| Address (DEC) | Description | Display | VALUE |
| 0~3 | Parameter page signature | ASCII | 4Fh, 4Eh, 46h, 49h |
| 4~5 | ONFI Revision number | HEX | 00h, 00h |
| 6~7 | Features supported | HEX | 00h, 00h |
| 8~9 | Optional commands supported | HEX | 06h, 00h |
| 10~31 | Reserved (0) | HEX | ALL 00h |
| 32~43 | Device manufacturer (12 Bytes ASCII characters) | ASCII | 45h, 74h, 72h, 6Fh, 6Eh, 20h, 20h, 20h, 20h, 20h, 20h, 20h, 20h |
| 44~63 | Device model (20Bytes ASCII characters) | ASCII | 45h, 4Dh, 37h, 38h, 44h, 30h, 34h, 34h, 56h, 43h, 4Dh, 2Dh, 48h, 20h, 20h, 20h, 20h, 20h, 20h, 20h, 20h, 20h, 20h |
| | EM78D044VCM-H | | |
| | EM78E044VCD-H | | |
| 64 | JEDEC manufacturer ID | HEX | D5h |
| 65~66 | Date code | HEX | 00h, 00h |
| 67~79 | Reserved (0) | HEX | ALL 00h |
| 80~83 | Number of data bytes per page | HEX | 00h, 08h, 00h, 00h (Page size = 2048 bytes) |
| 84~85 | Number of spare bytes per page | HEX | 80h, 00h (Spare 128) |
| 86~89 | Number of data bytes per partial page | HEX | 00h, 00h, 00h, 00h |
| 90~91 | Number of spare bytes per partial page | HEX | 00h, 00h |
| 92~95 | Number of pages per block | HEX | 40h, 00h, 00h, 00h |
| 96~99 | Number of blocks per logical unit (LUN) | HEX | 00h, 08h, 00h, 00h (Block=2048) 00h, 10h, 00h, 00h (Block=4096) |
| 100 | Number of logical units (LUNs) | HEX | 01h |
| 101 | Number of address cycles | HEX | 00h |
| 102 | Number of bits per cell | HEX | 01h |
| 103~104 | Bad blocks maximum per LUN | HEX | 28h, 00h (Block=2048) 50h, 00h (Block=4096) |
| 105~106 | Block endurance | HEX | 06h, 04h |
| 107 | Guaranteed valid blocks at beginning of target | HEX | 01h |
| 108~109 | Block endurance for guaranteed valid blocks | HEX | 00h, 00h |
| 110 | Number of programs per page | HEX | 01h |
| 111 | Partial programming attributes | HEX | 00h |
| 112 | Number of bits ECC correctability | HEX | 08h |
| 113 | Number of interleaved address bits | HEX | 00h |
| 114 | Interleaved operation attributes | HEX | 00h |
| 115~127 | Reserved (0) | HEX | ALL 00h |
| 128 | I/O pin capacitance | HEX | 00h |
| 129~130 | Timing mode support | HEX | 00h, 00h |
| 131~132 | Program cache timing mode support | HEX | 00h, 00h |
| 133~134 | tPROG Maximum page program time (us) | HEX | BCh, 02h |
| 135~136 | tBERS Maximum block erase time (us) | HEX | B8h, 0Bh |
| 137~138 | tR Maximum page read time (us) | HEX | 46h, 00h (Page size = 2048 bytes) |
| 139~140 | tCCS Minimum change column setup time (ns) | HEX | 00h, 00h |
| 141~163 | Reserved (0) | HEX | ALL 00h |
| 164~165 | Vendor specific Revision number | HEX | 00h, 00h |
| 166~253 | Vendor specific | HEX | ALL 00h |
| 254~255 | Integrity CRC | HEX | (SEE THE NOTES 1) |
| 256~511 | Value of Address 0~255 | HEX | Same as address 0~255 |
| 512~767 | Value of Address 0~255 | HEX | Same as address 0~255 |
| 768~1023 | Value of Address 0~255 | HEX | Same as address 0~255 |
| 1024+ | Additional redundant parameter pages | HEX | ALL FFh |

Note 1: (Source : ONFI_1.0_GOLD)

The CRC shall be calculated using the following 16-bit generator polynomial : $G(X) = X^{16} + X^{15} + X^2 + 1$

The CRC calculation covers all of data between byte 0 and byte 253 of the parameter page inclusive.

This polynomial in hex may be represented as 8005h.

The CRC value shall be initialized with a value of 4F4Eh before the calculation begins.

12 Block Protection

The block lock feature provides the ability to protect the entire device, or ranges of blocks, from the PROGRAM and ERASE commands. After power-up, the device is in the “locked” state, i.e., feature bits BP0, BP1 and BP2 are set to 1, INV, CMP and BRWD are set to 0. Some block operations relating to the block protection are listed as follows:

- SET FEATURE command must be issued to alter the state of protection feature bit.
- When BRWD is set and WP# is LOW, none of the writable protection feature bits can be set.
- When a PROGRAM/ERASE command is issued to a locked block, status bit OIP in status register (C0H) remains 0. The status register (C0H) will return 08H when a PROGRAM command is issued to program a locked block. The status register (C0H) will return 04H when an ERASE command is issued to erase a locked block.
- When WP# is not LOW, user can issue SET FEATURE command and use the protection register (A0H) and the block protect bits table below to alter the protection rows.

Table 12-1. Block Protection Bits Table

| CMP | INV | BP2 | BP1 | BP0 | Protect Rows |
|-----|-----|-----|-----|-----|----------------------|
| X | X | 0 | 0 | 0 | All unlocked |
| 0 | 0 | 0 | 0 | 1 | Upper 1/64 locked |
| 0 | 0 | 0 | 1 | 0 | Upper 1/32 locked |
| 0 | 0 | 0 | 1 | 1 | Upper 1/16 locked |
| 0 | 0 | 1 | 0 | 0 | Upper 1/8 locked |
| 0 | 0 | 1 | 0 | 1 | Upper 1/4 locked |
| 0 | 0 | 1 | 1 | 0 | Upper 1/2 locked |
| X | X | 1 | 1 | 1 | All locked (Default) |
| 0 | 1 | 0 | 0 | 1 | Lower 1/64 locked |
| 0 | 1 | 0 | 1 | 0 | Lower 1/32 locked |
| 0 | 1 | 0 | 1 | 1 | Lower 1/16 locked |
| 0 | 1 | 1 | 0 | 0 | Lower 1/8 locked |
| 0 | 1 | 1 | 0 | 1 | Lower 1/4 locked |
| 0 | 1 | 1 | 1 | 0 | Lower 1/2 locked |
| 1 | 0 | 0 | 0 | 1 | Lower 63/64 locked |
| 1 | 0 | 0 | 1 | 0 | Lower 31/32 locked |
| 1 | 0 | 0 | 1 | 1 | Lower 15/16 locked |
| 1 | 0 | 1 | 0 | 0 | Lower 7/8 locked |
| 1 | 0 | 1 | 0 | 1 | Lower 3/4 locked |
| 1 | 0 | 1 | 1 | 0 | Block 0 |
| 1 | 1 | 0 | 0 | 1 | Upper 63/64 locked |
| 1 | 1 | 0 | 1 | 0 | Upper 31/32 locked |
| 1 | 1 | 0 | 1 | 1 | Upper 15/16 locked |
| 1 | 1 | 1 | 0 | 0 | Upper 7/8 locked |
| 1 | 1 | 1 | 0 | 1 | Upper 3/4 locked |
| 1 | 1 | 1 | 1 | 0 | Block 0 |

13 Status Register

The content of status register can be read by issuing the GET FEATURE (0FH) command, followed by the status register address C0H. The meaning of each bit in status register is listed as follows:

Table 13-1. Status Register Bit Description

| Bit | Name | Description |
|--------------|-----------------------|--|
| P_FAIL | Program Fail | This bit indicates that a program failure has occurred. It will also be set if the user attempts to program an invalid address or a protected region, including the OTP area. This bit is cleared during the PROGRAM EXECUTE command sequence or a RESET command. |
| E_FAIL | Erase Fail | This bit indicates that an erase failure has occurred. It will also be set if the user attempts to erase a locked region. This bit is cleared at the start of the BLOCK ERASE command sequence or the RESET command. |
| WEL | Write Enable Latch | This bit indicates that the current status of the write enable latch(WEL) and must be set (WEL = 1), prior to issuing a PROGRAM EXECUTE or BLOCK ERASE command. It is set by issuing the WRITE ENABLE command. WEL can also be disabled (WEL = 0), by issuing the WRITE DISABLE command. |
| OIP | Operation In Progress | This bit is set when a PROGRAM EXECUTE, PAGE READ, BLOCK ERASE or RESET command is executing, indicating the device is busy. When the bit is 0, the interface is in the ready state. |
| ECCS1, ECCS0 | ECC Status | This bit provides ECC status as follows: 00b = No bit errors were detected 01b = bit error was detected and corrected 10b = bit error was detected and not corrected 11b = bit error was detected and corrected, error bit number = ECC max which is according to extended register. ECCS is set to 00b either following a RESET, or at the beginning of the READ. It is then updated after the device completes a valid operation. After power-on RESET, ECC status is set to reflect the contents of block 0, page 0. |

Notes: The ECC status of register C0H will be cleared when ECC is disabled.

14 Block Management

A NAND Flash device is specified to have a minimum number of valid blocks of the total available blocks per die, which means the devices may have blocks that are invalid when shipped from the factory. The factory identifies invalid blocks before shipping by attempting to program the bad-block mark into every location in the first page of each invalid block. It may not be possible to program every location in an invalid block with the bad-block mark but the first spare area location in each bad block is guaranteed to contain the bad-block mark. System software should initially check the first spare area location for non-FFh data on the first page of each block prior to performing any program or erase operations on the NAND Flash device. If the data is 00h, define the block as a bad block.

Table 14-1. Valid Block Information

| | | |
|--------------------------------|---------|------|
| Total available blocks | 2048 | 4096 |
| Minimum number of valid blocks | 2008 | 4016 |
| The bad block mark | All 00h | |

15 Power-On Process

When the chip reached the power on level, the internal power on reset signal will be released. The device can response host commands after tPUW (Max 4ms). The host should issue GET FEATURE (0Fh). The device will use the OIP bit in the status register to inform the host that initialization in power-on process is completed. Setting OIP bit to 1 indicates that the device is still initializing. Setting the OIP bit to 0 indicates that the power on process is finished. If OIP bit is 1, the host will repeatedly issues GET FEATURE (0Fh) command to monitor the power-on process until the OIP bit is set to 0.

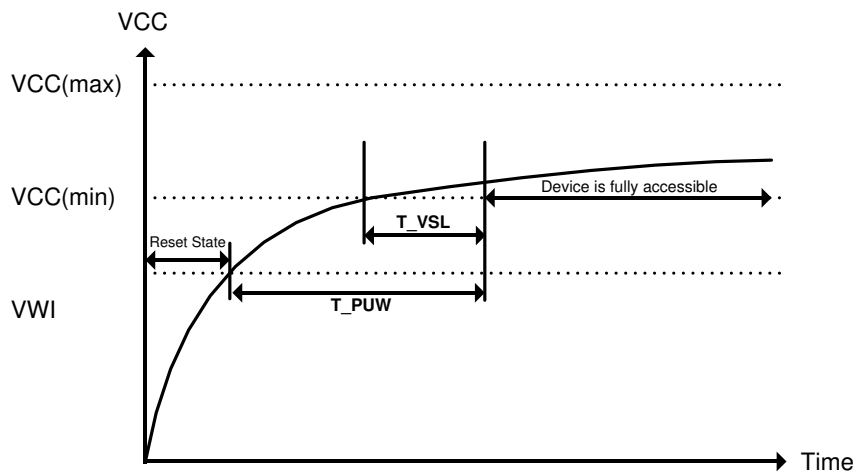

Figure 15-1. Power-On Process

Table 15-1. Power-On Process Parameters

| Parameters | Symbol | Min | Typical | Max | Unit | |
|--|--------|-----|---------|-----|------|---|
| VCC (min) to CS# Low | tVSL | 50 | - | 500 | us | |
| Time Delay Before Read/Write Instruction | tPUW | - | 3 | 4 | ms | |
| Write Inhibit Threshold Voltage | 1.8V | vWI | 1.5 | - | - | V |

16 Electrical Characteristics

Table 16-1. SPI NAND DC Characteristics

| Parameters | Symbol | Min | Typical | Max | Unit |
|--------------------------------------|--------|-----------|---------|-----------|------|
| SPI Supply Voltage | VCC | 1.7 | 1.8 | 1.98 | V |
| VCC standby current | ISB | - | 30 | 120 | uA |
| VCC active current (sequential read) | ICC1 | - | 20 | 30 | mA |
| VCC active current (Program) | ICC2 | - | 20 | 30 | mA |
| VCC active current (Erase) | ICC3 | - | 25 | 30 | mA |
| Input low level | V_IL | -0.3 | - | 0.2 x VCC | V |
| Input high level | V_IH | 0.8 x VCC | - | VCC + 0.3 | V |
| Output High Voltage | V_OH | VCC - 0.2 | - | - | V |
| Output Low Voltage | V_OL | - | - | 0.2 | V |
| Input Leakage Current | I_LI | - | - | ±10 | uA |
| Output Leakage Current | I_LO | - | - | ±10 | uA |

Table 16-2. Capacitance Characteristics

| Parameters | Symbol | Min | Typical | Max | Unit | Condition |
|--------------------------|--------|-----|---------|-----|------|-----------|
| Input Capacitance | CIN | - | - | 3.5 | pF | VIN=0V |
| Output Capacitance | COUT | - | - | 3.5 | pF | VOUT=0V |
| Load Capacitance | CL | 10 | | | pF | |
| Input Rise and Fall time | | - | - | 5 | ns | |

Table 16-3. AC Time Characteristics ($T_A = -40 \sim 85^\circ\text{C}$, $C_L = 10\text{pF}$)

| Parameters | Symbol | Min | Typical | Max | Unit |
|--|--------|-----|---------|-----|------|
| Clock Frequency | FC | - | - | 100 | MHz |
| Page Program Time | tPROG | - | 600 | 700 | us |
| Clock High Time | tCLH | 5 | - | - | ns |
| Clock Low Time | tCLL | 5 | - | - | ns |
| Command deselect Time | tSHSL | 20 | | | ns |
| CS# Setup Time | tSLCH | 4 | - | - | ns |
| CS# Hold Time | tCHSL | 4 | - | - | ns |
| Data In Setup Time | tDVCH | 2 | - | - | ns |
| Data In Hold Time | tCHDX | 4 | - | - | ns |
| Output Hold time | tCLQX | 2.7 | - | - | ns |
| Clock to output Valid | tCLQV | - | - | 9.5 | ns |
| CS# High to Output Invalid | tSHQZ | - | - | 4 | ns |
| CS# Active Hold time relative to SCLK | tCHSH | 4 | - | - | ns |
| CS# Not Active Setup time relative to SCLK | tSHCH | 4 | - | - | ns |
| Hold# hold time relative to SCLK | tCH | 5 | - | - | ns |
| Hold# non-active hold time relative to SCLK | tCD | 5 | - | - | ns |
| Hold# setup time relative to SCLK | tHD | 5 | - | - | ns |
| Hold# non-active setup time relative to SCLK | tHC | 5 | - | - | ns |
| Hold# to output High-Z | tHZ | - | - | 10 | ns |
| Hold# to output Low-Z | tLZ | - | - | 10 | ns |
| WP# setup time | tWPS | 20 | - | - | ns |
| WP# hold time | tWPH | 100 | - | - | ns |

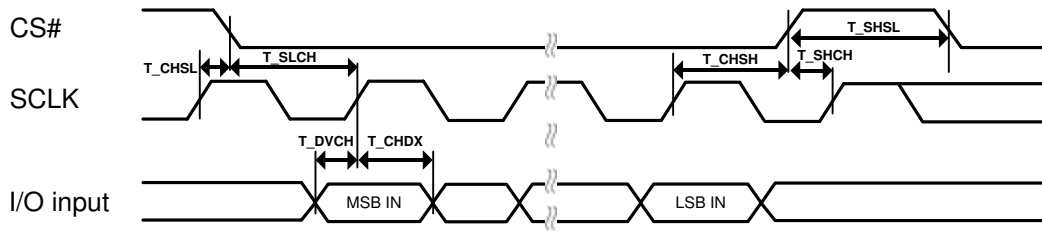

Figure 16-1. Serial Input Timing

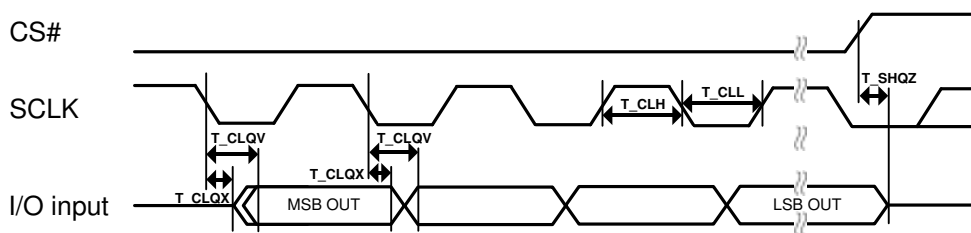

Figure 16-2. Serial Output Timing

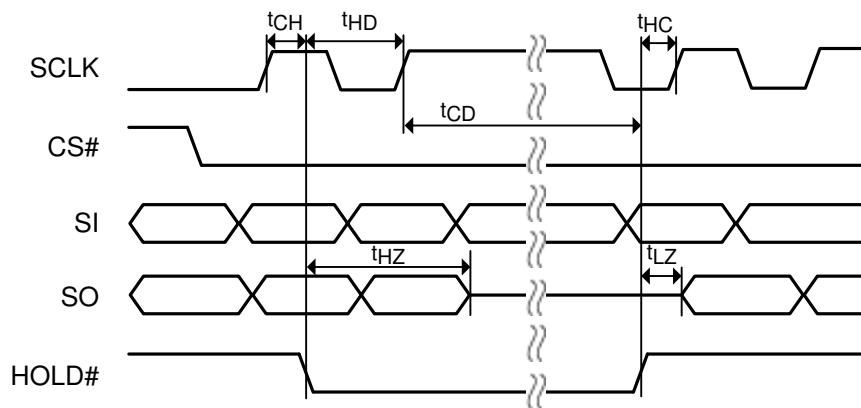

Figure 16-3. Hold# Timing

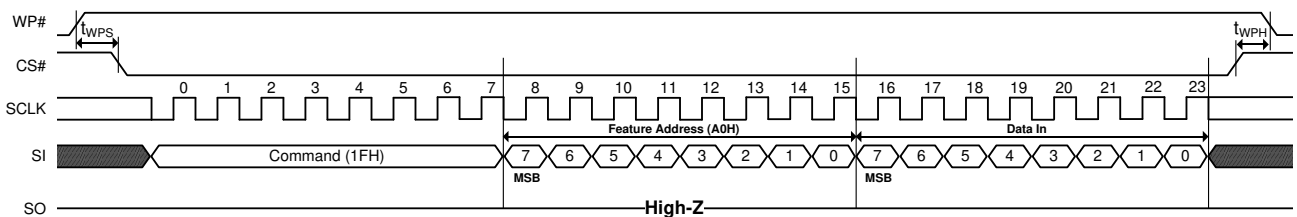

Figure 16-4. WP# Timing

17 Package Outline Information

Table 17-1. LGA (8 x 6 x 0.8mm) Dimension Table

| Symbol | Dimension (MM) | | | Dimension (MIL) | | |
|--------|----------------|-------|-------|-----------------|---------|---------|
| | Min | Nom | Max | Min | Nom | Max |
| A | 0.700 | 0.750 | 0.800 | 27.559 | 29.528 | 31.496 |
| (A1) | 0.500 | 0.550 | 0.600 | 19.685 | 21.654 | 23.622 |
| A2 | - | 0.210 | - | - | 8.268 | - |
| b | 0.350 | 0.400 | 0.480 | 13.780 | 15.748 | 18.898 |
| D | 7.900 | 8.000 | 8.100 | 311.023 | 314.960 | 318.897 |
| E | 5.900 | 6.000 | 6.100 | 232.283 | 236.220 | 240.157 |
| e | 1.270 | | | 50.000 | | |
| L | 0.450 | 0.500 | 0.550 | 17.717 | 19.685 | 21.654 |

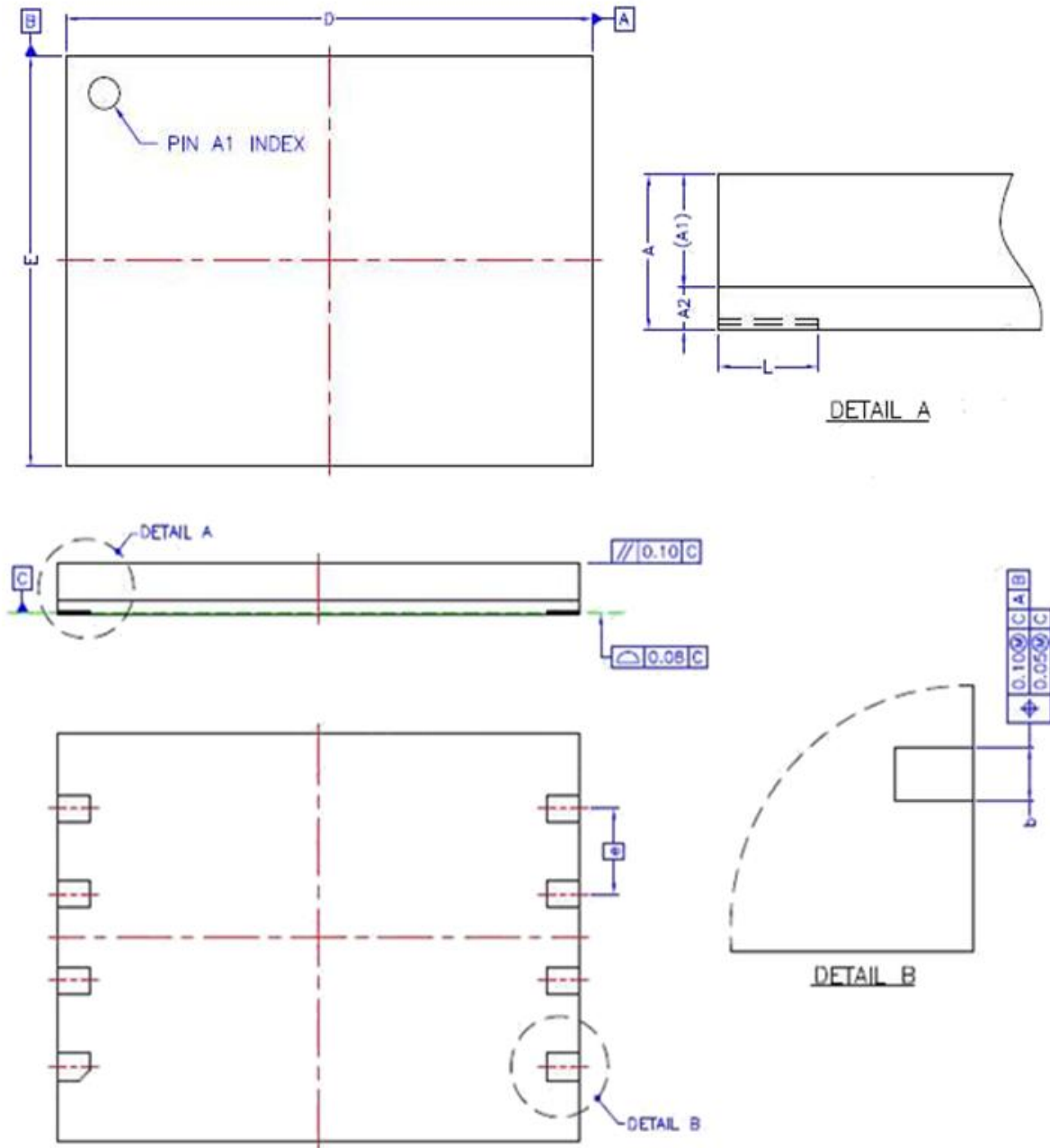

Figure 17-1. LGA (8 x 6 x 0.8mm) Package Outline Drawing Information